

4310110

Model 431

Shoppertron

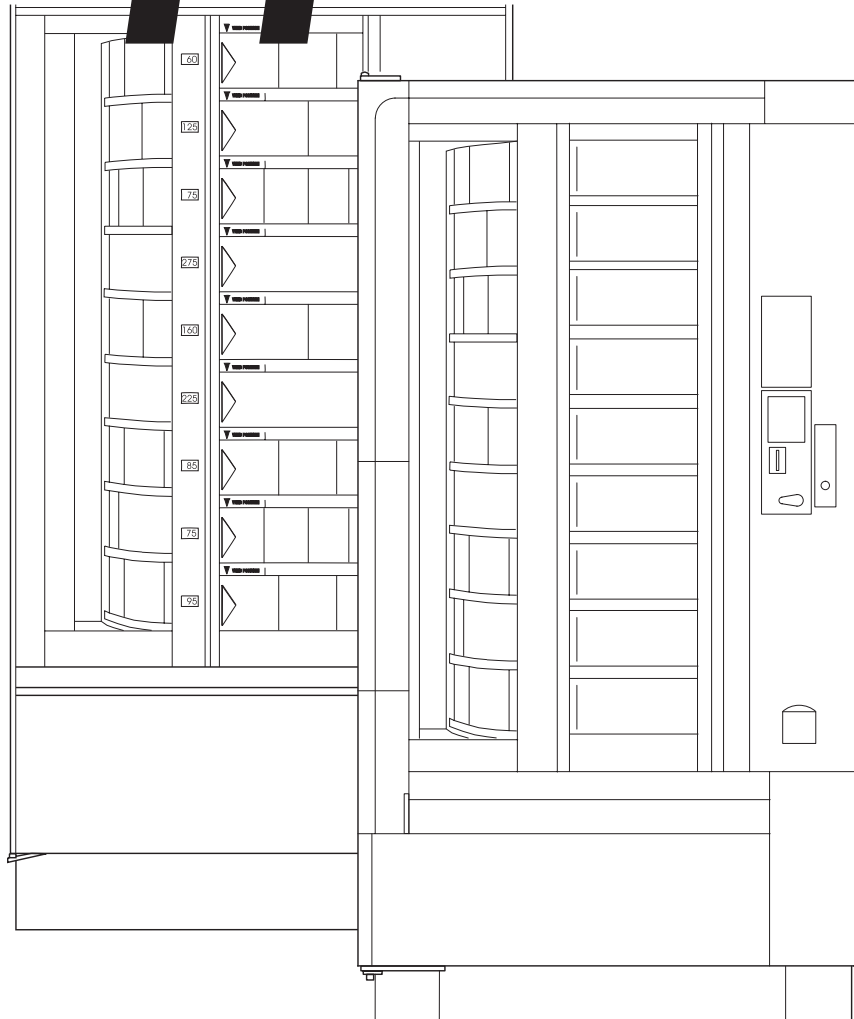

PARTS MANUAL

CRANE

MERCHANDISING SYSTEMS™ A Crane Co. Company
CMS PARTS & SUPPORT

12955 Enterprise Way
Bridgeton, Missouri 63044-1200
(314) 298-3500 / (800) 621-7278
www.CraneMS.com

Copyright© 9-03

4310110

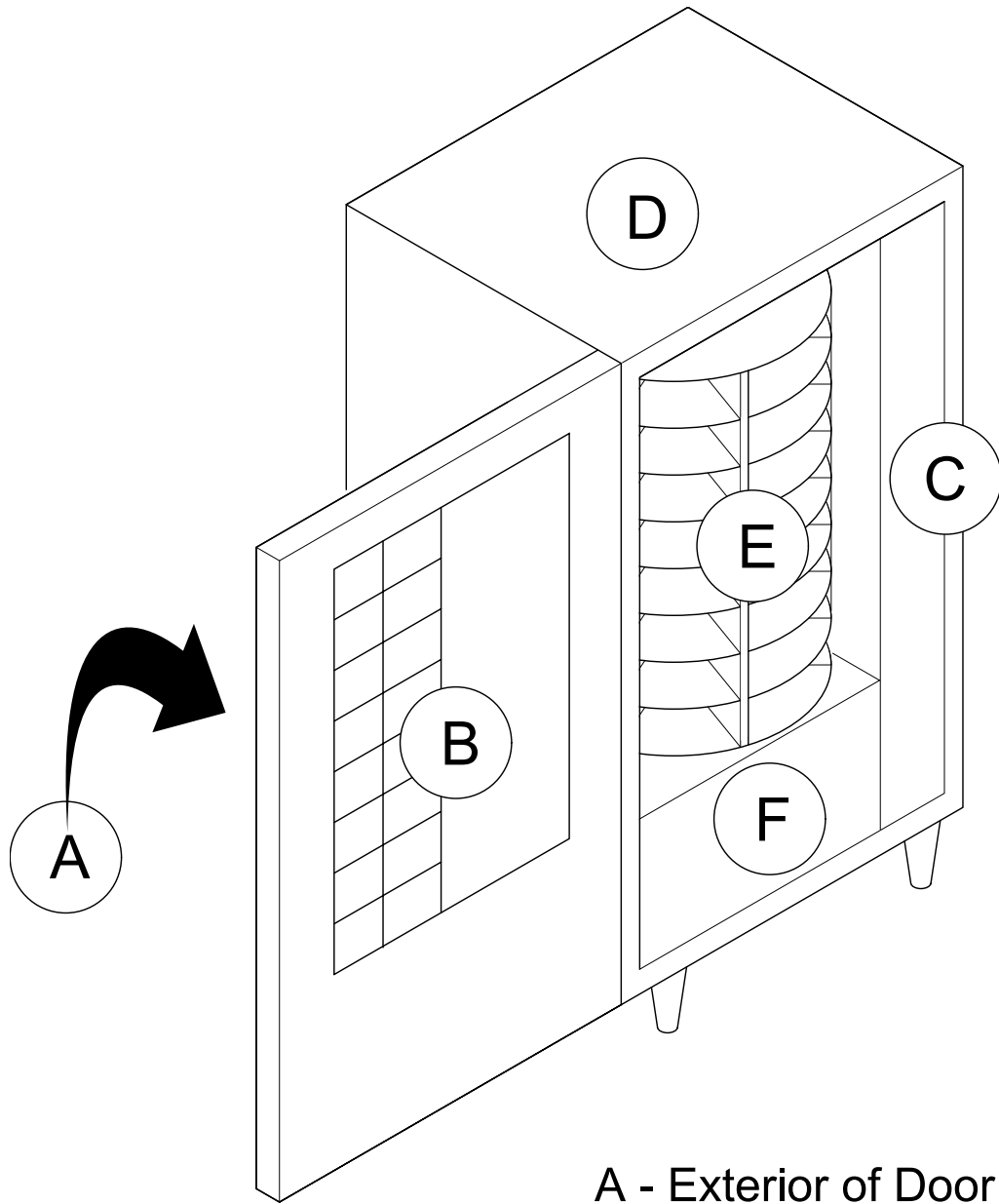

- A - Exterior of Door
- B - Interior of Door
- C - Monetary
- D - Cabinet
- E - Turret
- F - Refrigeration
- G - Miscellaneous

List of Figures

Section A: Exterior Door	1
FIGURE 1: Standard Trim.....	2
FIGURE 2: Millennia Trim.....	4
Section B: Interior of Door	8
FIGURE 3: Miscellaneous Door (Part 1 of 4).....	8
FIGURE 4: Miscellaneous Door (Part 2 of 4).....	10
FIGURE 5: Miscellaneous Door (Part 3 of 4).....	12
FIGURE 6: Miscellaneous Door (Part 4 of 4).....	14
FIGURE 7: Glass Assembly.....	16
FIGURE 8: Mechanism Cover & Light Bracket Assembly	18
FIGURE 9: Lower Door Electrical Assembly.....	20
FIGURE 10: Lockbar and Panel Mechanism Assembly	22
FIGURE 11: Door Lock and Handle Assembly	24
FIGURE 12: Lift Handle Lock Assembly	26
FIGURE 13: Door Insulation (Part 1 of 2)	28
FIGURE 14: Door Insulation (Part 2 of 2)	30
FIGURE 15: Screen Assembly	32
FIGURE 16: Scavenger Assembly.....	34
Section C: Monetary	36
FIGURE 17: Monetary Door.....	36
FIGURE 18: Monetary Door Electronics Assembly	38
FIGURE 19: Instruction Inserts - Upper	40
FIGURE 20: Instruction Inserts - Lower	41
FIGURE 21: Monetary Compartment.....	44
FIGURE 22: Monetary Compartment Latch and Plate Assembly.....	46
Section D: Cabinet.....	48
FIGURE 23: Cabinet Assembly (Part 1 of 4)	48
FIGURE 24: Cabinet Assembly (Part 2 of 4)	50
FIGURE 25: Cabinet Assembly (Part 3 of 4)	52
FIGURE 26: Cabinet Assembly (Part 4 of 4)	54
FIGURE 27: Light Assembly - Hinge Side	56
FIGURE 28: Light Assembly - Lock Side	58
FIGURE 29: Duct - Blower Assembly	60
FIGURE 30: Upper Hinge Assembly.....	62
FIGURE 31: Lower Hinge Assembly.....	64
Section E: Turret.....	66
FIGURE 32: Turret Assembly	66
FIGURE 33: Drum Assembly	68
FIGURE 34: Drive Motor Assembly	70

List of Figures

Section F: Refrigeration	72
FIGURE 35: Compressor Assembly	72
FIGURE 36: Condenser.....	74
FIGURE 37: Insulation	76
FIGURE 38: Evaporator Lid Fan Assembly	78
Section G: Miscellaneous	80
FIGURE 39: Stop Pin/Solenoid Assembly	80
FIGURE 40: Power Panel Assembly - 115 V.....	82
FIGURE 41: Power Panel Assembly - U.K.	84
FIGURE 42: Power Panel Assembly - 230 V.....	86
FIGURE 43: Base Plate Accessory	88
FIGURE 44: Wiring Diagram - 120V.....	90
FIGURE 45: Wiring Diagram - 230V.....	91

List of Tables

Section A: Exterior Door	1
TABLE 1: Standard Trim	3
TABLE 1A: Trim Component By Style	3
TABLE 2: Millennia Trim.....	5
TABLE 2A: Trim Panel Availability - Top Trim Panel.....	6
TABLE 2B: Trim Panel Availability - Monetary Trim Panel	6
TABLE 2C: Trim Panel Availability - Bottom Trim Panel.....	7
Section B: Interior of Door	8
TABLE 3: Miscellaneous Door (Part 1 of 4)	9
TABLE 4: Miscellaneous Door (Part 2 of 4)	11
TABLE 5: Miscellaneous Door (Part 3 of 4)	13
TABLE 6: Miscellaneous Door (Part 4 of 4)	15
TABLE 7: Glass Assembly	17
TABLE 8: Mechanism Cover & Light Bracket Assembly	19
TABLE 9: Lower Door Electrical Assembly	21
TABLE 10: Lockbar and Panel Mechanism Assembly	23
TABLE 11: Door Lock and Handle Assembly.....	25
TABLE 12: Lift Handle Lock Assembly.....	27
TABLE 13: Door Insulation (Part 1 of 2)	29
TABLE 14: Door Insulation (Part 2 of 2)	31
TABLE 15: Screen Assembly	33
TABLE 16: Scavenger Assembly	35
Section C: Monetary	36
TABLE 17: Monetary Door	37
TABLE 18: Monetary Door Electronics Assembly	39
TABLE 19: Validator Options	43
TABLE 20: Card Reader Options	43
TABLE 21: Monetary Compartment	45
TABLE 21A: Coin Mechanism Options	45
TABLE 22: Monetary Compartment Latch and Plate Assembly.....	47
Section D: Cabinet	48
TABLE 23: Cabinet Assembly (Part 1 of 4)	49
TABLE 24: Cabinet Assembly (Part 2 of 4)	51
TABLE 25: Cabinet Assembly (Part 3 of 4)	53
TABLE 26: Cabinet Assembly (Part 4 of 4)	55
TABLE 27: Light Assembly - Hinge Side.....	57
TABLE 28: Light Assembly - Lock Side.....	59
TABLE 29: Duct - Blower Assembly	61
TABLE 30: Upper Hinge Assembly	63
TABLE 31: Lower Hinge Assembly	65

List of Tables

Section E: Turret	66
TABLE 32: Turret Assembly	67
TABLE 33: Drum Assembly	69
TABLE 34: Drive Motor Assembly	71
Section F: Refrigeration	72
TABLE 35: Compressor Assembly	73
TABLE 36: Condenser	75
TABLE 37: Insulation	77
TABLE 38: Evaporator Lid Fan Assembly	79
Section G: Miscellaneous	80
TABLE 39: Stop Pin/Solenoid Assembly	81
TABLE 40: Power Panel Assembly - 115 V	83
TABLE 41: Power Panel Assembly - U.K.	85
TABLE 42: Power Panel Assembly - 230 V	87
TABLE 43: Base Plate Accessory	89
TABLE 44: Wire Harnesses	92
TABLE 45: Bag Assembly B4310000 - US	94

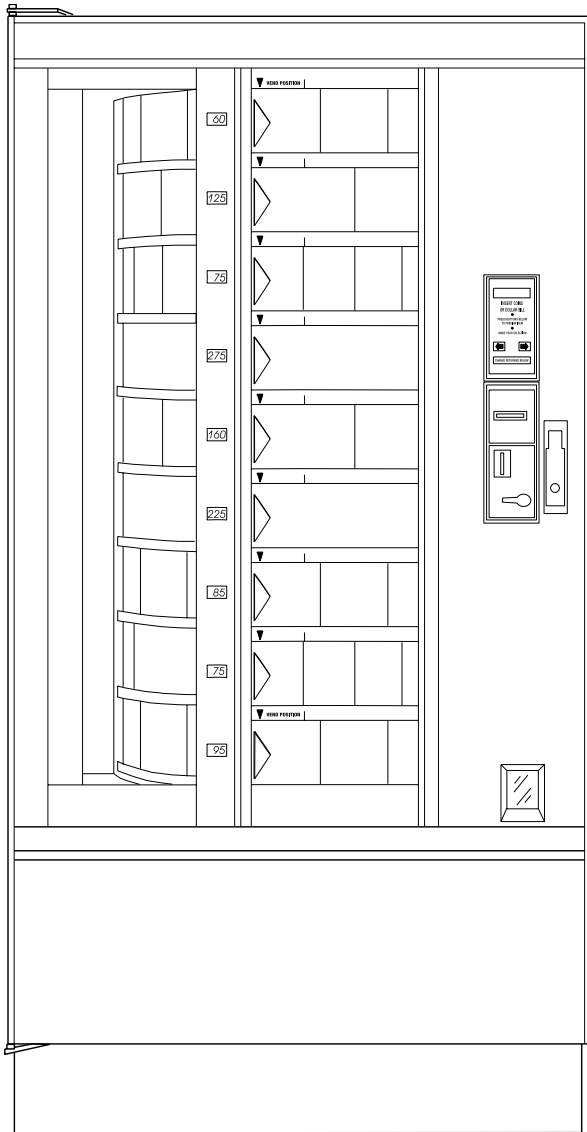

STANDARD

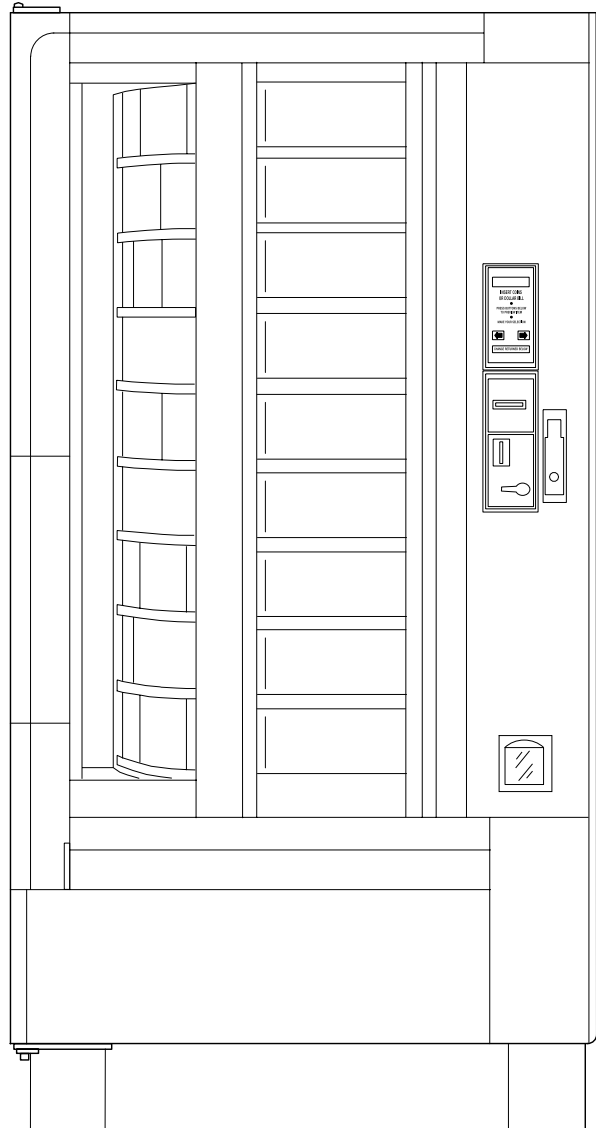

MILLENNIA

431p0074

SHOPPERTRON MODEL 431

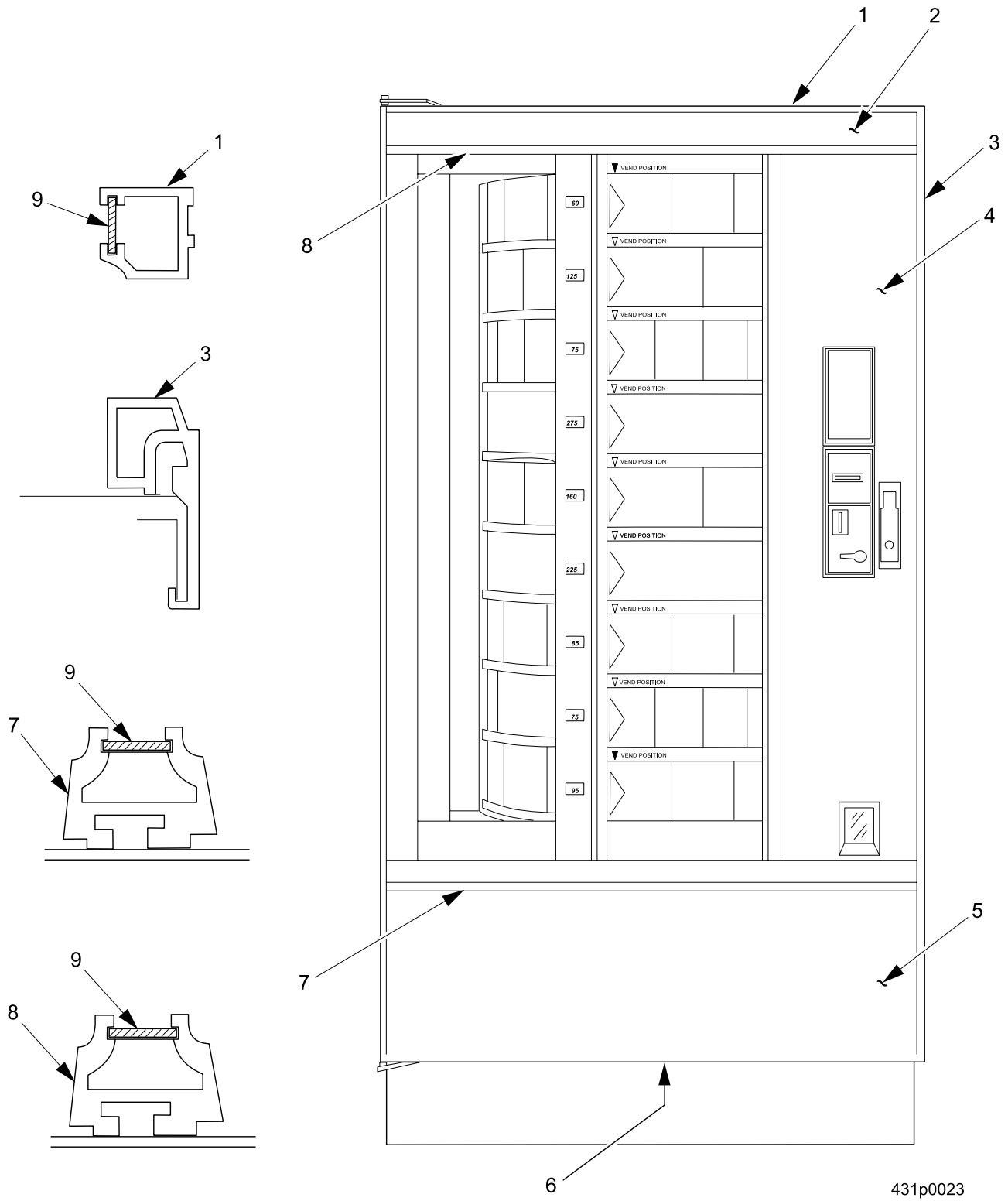

FIGURE 1: STANDARD TRIM

TABLE 1: STANDARD TRIM

INDEX	PART NUMBER	DESCRIPTION	QTY
1	--	TOP PANEL (SEE TABLE 2A FOR DETAILS)	1
2	--	TOP TRIM (SEE TABLE 1A FOR DETAILS)	1
3	--	SIDE TRIM (SEE TABLE 1A FOR DETAILS)	2
4	--	MONETARY PANEL (SEE TABLE 2B FOR DETAILS)	1
5	--	BOTTOM PANEL (SEE TABLE 2C FOR DETAILS)	1
6	6232099	EDGE PROTECTOR - BOTTOM	1
7	--	HORIZONTAL TRIM (BOTTOM) (SEE TABLE 1A FOR DETAILS)	1
8	--	HORIZONTAL TRIM (TOP) (SEE TABLE 1A FOR DETAILS)	1
9	1302479	TRIM INSERT - BLACK	3

TABLE 1A: TRIM COMPONENT BY STYLE

INDEX	TRIM COMPONENT PART NUMBERS BY STYLE	
	IMPERIAL CROWN	SIGNATURE SERIES
2	4302115	4302115
3	4302274	4302272
7	1302478	1302478
8	4302121	4302121
	CAN-CAN	ARA
2	4302124	4302280
		4302282
3	4302272	4302274
7	1302478	1302478
8	4302121	4302121

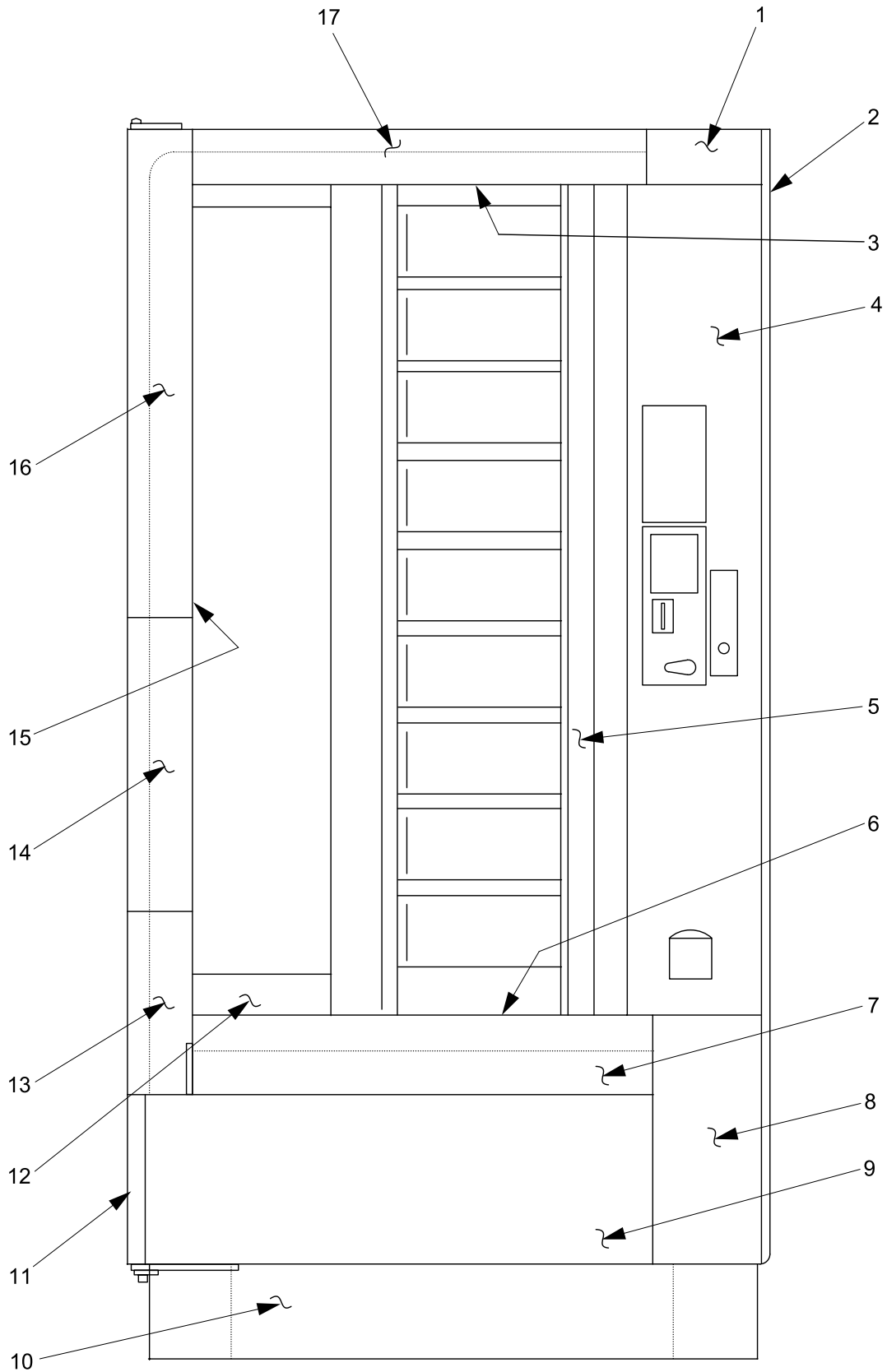

FIGURE 2: MILLENNIA TRIM

431p0113

TABLE 2: MILLENNIA TRIM

INDEX	PART NUMBER	DESCRIPTION	QTY
1	4312202	HORIZONTAL TRIM - SHOPPER	1
2	4312090	TRIM - DOOR SIDE	1
3	4312096	TRIM - DOOR	1
4	4312205	MONETARY TRIM - SHOPPER - "N"	1
5	4302109	TRIM - MONETARY	1
6	4312095	TRIM - DOOR - BOTTOM	1
7	4312201	HORIZONTAL TRIM - LOWER - SHOPPER - "L"	1
8	4312203	RIGHT HANDTRIM - LOWER SHP. - "O"	1
9	1572327	PANEL - BOTTOM TRIM - GRAY	1
	1572325	PANEL - BOTTOM TRIM - BLACK	
	1572432	PANEL - BOTTOM TRIM - SELECTA WHITE	
	4312231	PANEL - BOTTOM TRIM - BLACK ARA	
10	4311190	BASE PLATE & ACCESSORY - 38" - MILL. (SEE FIGURE 31)	OPT.
11	1572267	TRIM - LOWER - DOOR SIDE - GRAY	1
	1572324	TRIM - LOWER - DOOR SIDE - BLACK	
	4872013	TRIM - LOWER - DOOR SIDE - SELECTA WHITE	
12	4302079	RETAINER - GLASS - BOTTOM	1
	4312107	RETAINER - GLASS - BOTTOM	
13	4872009	LEFT HAND TRIM - BOTTOM - SELECTA WHITE	1
	4552060	LEFT HAND TRIM - BOTTOM - "E"	
	6312015	LEFT HANDTRIM - BOTTOM - MILLENNIA BLACK.	
14	6312014	LEFT HANDTRIM - MIDDLE - MILLENNIA BLACK.	1
	4872008	LEFT HAND TRIM - MIDDLE - SELECTA WHITE	
	4552059	LEFT HAND TRIM - MIDDLE - "D"	
15	4312094	TRIM - DOOR - LEFT	1
16	4872007	LEFT HAND TRIM - UPPER - SELECTA WHITE	1
	4552058	LEFT HAND TRIM - UPPER - "C"	
	6312013	L.EFT HAND TRIM - UPPER - MILLENNIA BLACK.	
--	1572258	DECAL - DOOR TRIM VERTICAL ASSEMBLY (USED WITH ITEM NUMBERS 13, 14, AND 16)	1
17	4312138	HORIZONTAL TRIM - TOP - SHOPPER - SELECTA WHITE	1
	4312200	HORIZONTAL TRIM - TOP - SHOPPER - "H1A"	
	4312146	HORIZONTAL TRIM - TOP - SHOPPER - BLACK	
--	1572236	DECAL - DOOR TRIM - HORIZONTAL 38 IN. FADING DOT PATTERN (USED WITH ITEM NUMBER 17)	1
--	4311007	PANEL - BACK - CABINET	1

TABLE 2A: TRIM PANEL AVAILABILITY - TOP TRIM PANEL

PART NUMBER	DESCRIPTION
4312236	ARA BLACK
4302373	BISON BLACK
1452225	BLACK HAIRCELL
6232309	BLACK PICA
4302285	CHES. LEATHER
4302288	COMP OAK
4302284	DOVE GREY
1452116	ENAMELED
1452117	FORMICA SPECIAL
4302415	MOROCCO GREY
1572128	NU WHITE
4312238	NV BLACK
1452062	PRESIDENTIAL WALNUT
6232224	SLATE
1452121	STAINLESS
3152447	STERLING
1452118	TEAK

TABLE 2B: TRIM PANEL AVAILABILITY - MONETARY TRIM PANEL

PART NUMBER	DESCRIPTION
4305100	NU WHITE
4305144	BISON
4305138	BLACK PICA
4315032	MILLENNIA - STD
4305010	MOROCCO
4315028	NV BLACK
4305145	PEWTER
4315054	SLATE
4305052	STERLING
4305113	DEBIT READER - NO COIN - STERLING
4305140	DEBIT READER - NO COIN - BLACK PICA
4305112	DEBIT READER - WITH COIN - STERLING
4305141	DEBIT READER - WITH COIN - BLACK PICA
4315043	DEBIT READER - WITH COIN
4315022	DEBIT READER - WITH COIN - MOROCCO
4315025	DEBIT READER - NO COIN - MOROCCO
4312116	DEBIT READER - NO COIN - BISON
4315040	TRIM - MONETARY - "N" - DEBITEK COIN - MILLENNIA
4312234	TRIM - MONETARY - ARA PHOTOFRESH

TABLE 2C: TRIM PANEL AVAILABILITY - BOTTOM TRIM PANEL

PART NUMBER	DESCRIPTION
1572104	BISON BLACK
1572107	BLACK PICA
1572110	BLACK HAIRCELL
1572167	BLANK
1572113	CHES. LEATHER
1572116	COMP. OAK
1572119	DOVE GREY
1572124	ENAMELED
1572127	FORMICA SPECIAL
4312048	MOROCCO GREY
1572131	NU WHITE
1572150	PRESIDENTIAL WALNUT
1572153	SLATE
4312028	STAINLESS
1572102	STERLING
1572158	TEAK

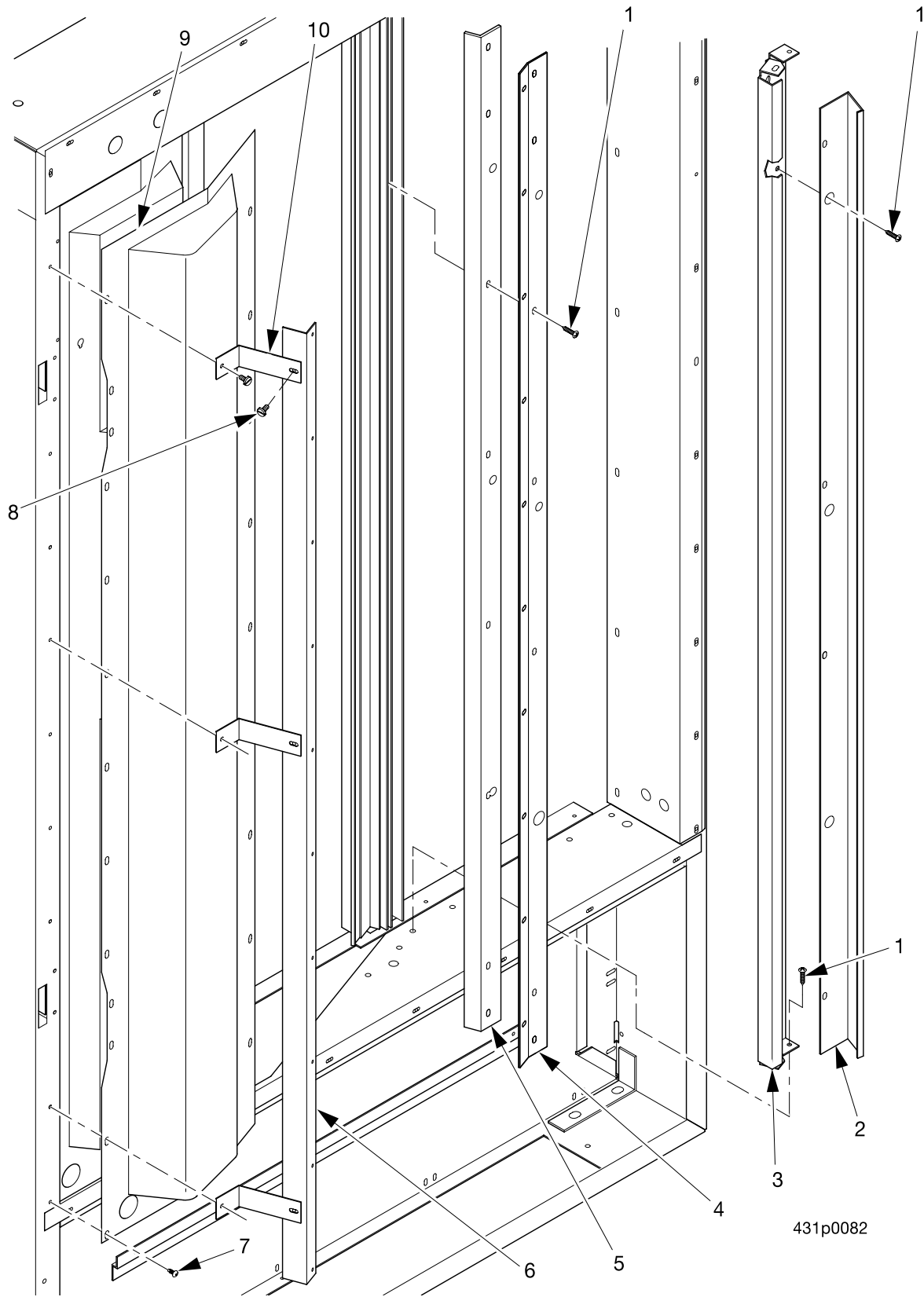
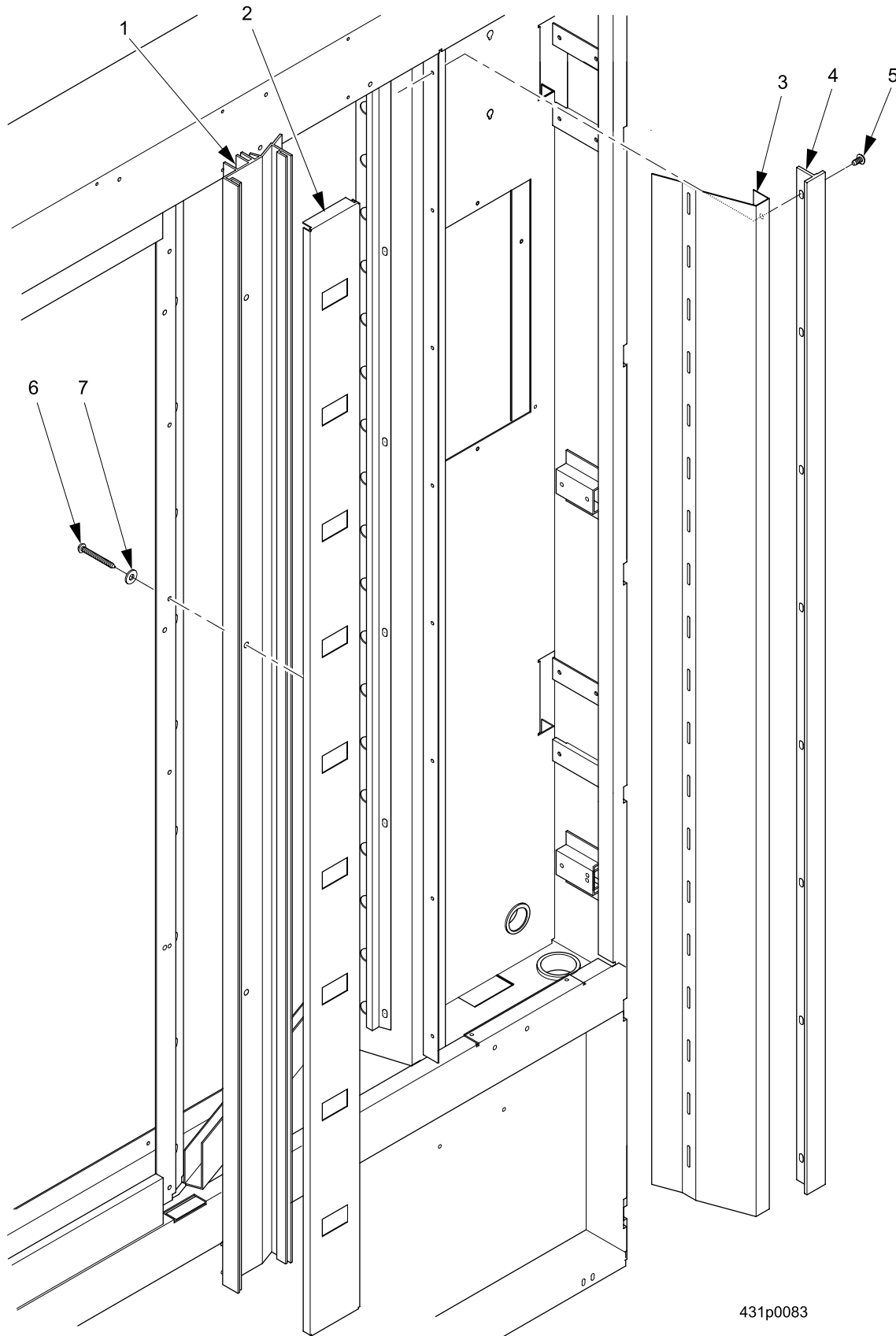

FIGURE 3: MISCELLANEOUS DOOR (PART 1 OF 4)

TABLE 3: MISCELLANEOUS DOOR (PART 1 OF 4)

INDEX	PART NUMBER	DESCRIPTION	QTY
1	9900160	SCREW - #8-18 X 1/2"PHIL.PAN HD.	--
2	4312084	BAFFLE - DOOR - .62 - WHITE	1
3	4302136	STIFFENER - CENTER POST	1
	4302391	STIFFENER - CENTER POST (BLACK)	
4	4302390	LOCATOR - DOOR GUIDE (BLACK)	1
	4302089	LOCATOR - DOOR GUIDE (WHITE)	
5	4302034	ANGLE - CENTER POST	1
6	4302106	ANGLE - SUPPORT - GUIDE	1
7	9900156	SCREW #8-32 X 1/2 RHS S/T	--
8	9900106	SCREW #8-32 X 3/8 ACORN HEX HD	--
9	4302030	LINER - DOOR - RIGHT	1
	4302386	LINER - DOOR - RIGHT (BLACK)	
10	4302181	SUPPORT - BRACKET	3



431p0083

FIGURE 4: MISCELLANEOUS DOOR (PART 2 OF 4)

TABLE 4: MISCELLANEOUS DOOR (PART 2 OF 4)

INDEX	PART NUMBER	DESCRIPTION	QTY
1	4302236	POST - CENTER - DOOR	1
2	4312067	VERTICAL PRICE DISPLAY ASSEMBLY	1
3	4312144	COVER - DUCT	1
4	4302109	TRIM - MONETARY	1
5	4312217	SCREW #8-32 X.50 PHILLIPS-PN HD	--
6	4312215	SCREW - #8-18 X 1 1/4 RHP TAPPING	--
7	9900035	WASHER - STL 7/16 X 3/16 X 3/64	--

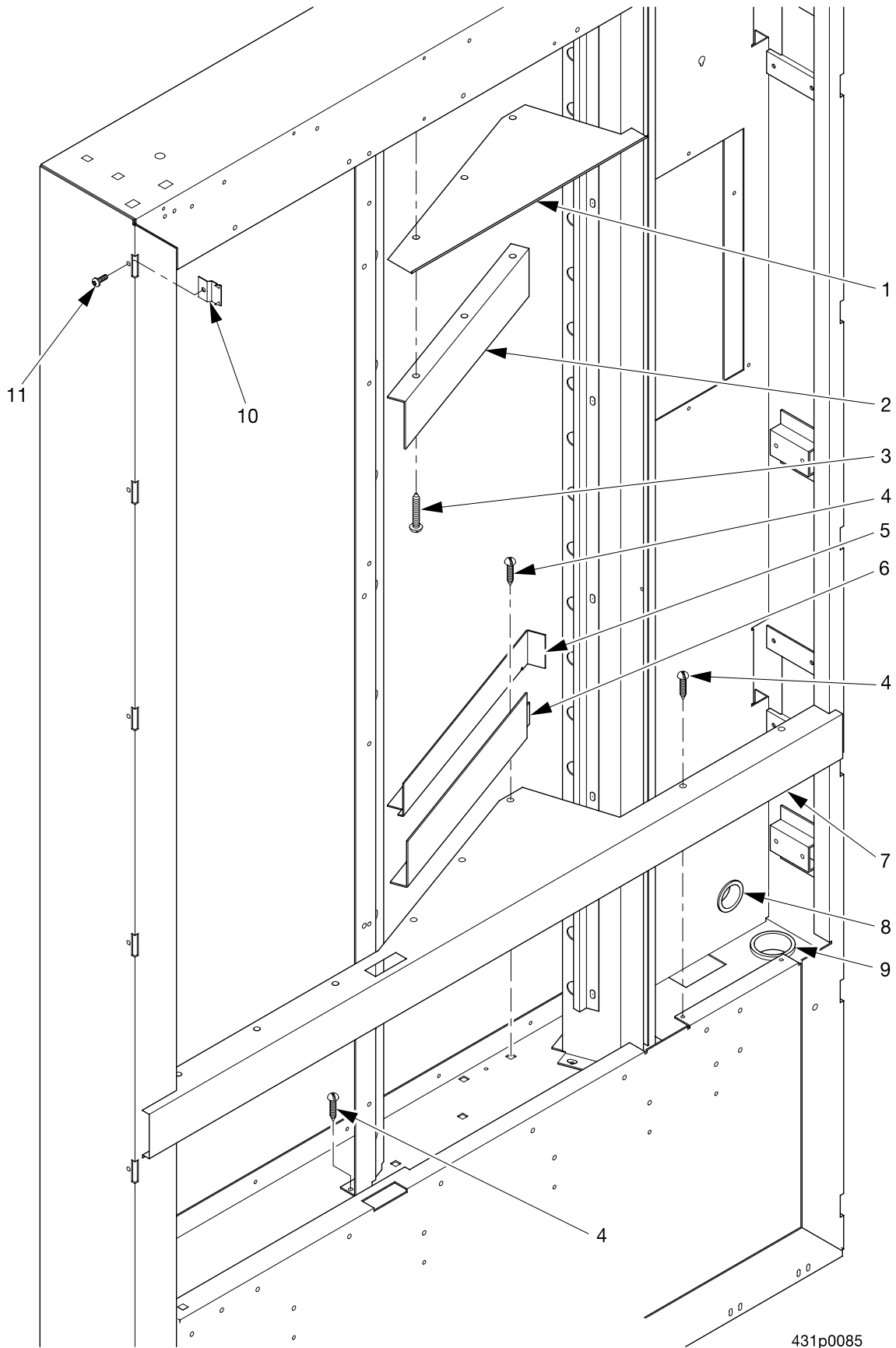

FIGURE 5: MISCELLANEOUS DOOR (PART 3 OF 4)

431p0085

TABLE 5: MISCELLANEOUS DOOR (PART 3 OF 4)

INDEX	PART NUMBER	DESCRIPTION	QTY
1	4312096	TRIM - DOOR	1
2	4312228	RETAINER - VEND DOOR - TOP - BLACK	1
3	4312215	SCREW - #8-18 X 1 1/4 RHP TAPPING	-
4	4312214	SCREW #8-18 X 3/4 RHP TAPPING	-
5	4302082	RETAINER - INSULATION - BOTTOM	1
6	4312227	RETAINER & PLATE ASSEMBLY - BOTTOM - BLACK	1
7	4302120	TRIM - DOOR - BOTTOM (STANDARD)	1
	4312095	TRIM - DOOR - BOTTOM (MILLENNIA)	
8	3106155	BUSHING #SB1000-12	1
9	6106021	BUSHING #SB1500-21	1
10	4302414	CLIP - DOOR TRIM	14
11	4312217	SCREW #8-32 X.50 PHILLIPS-PN HD	--

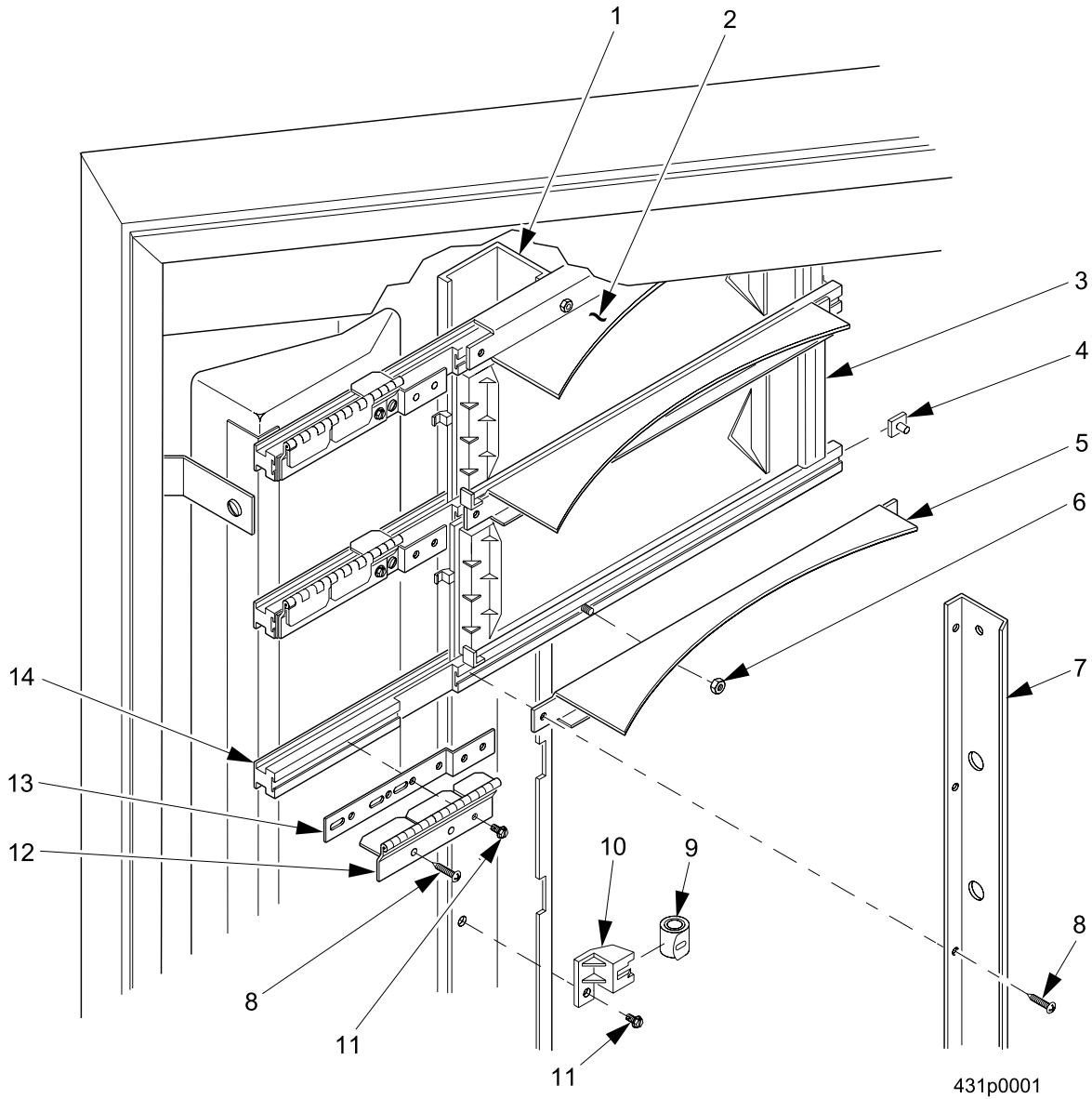
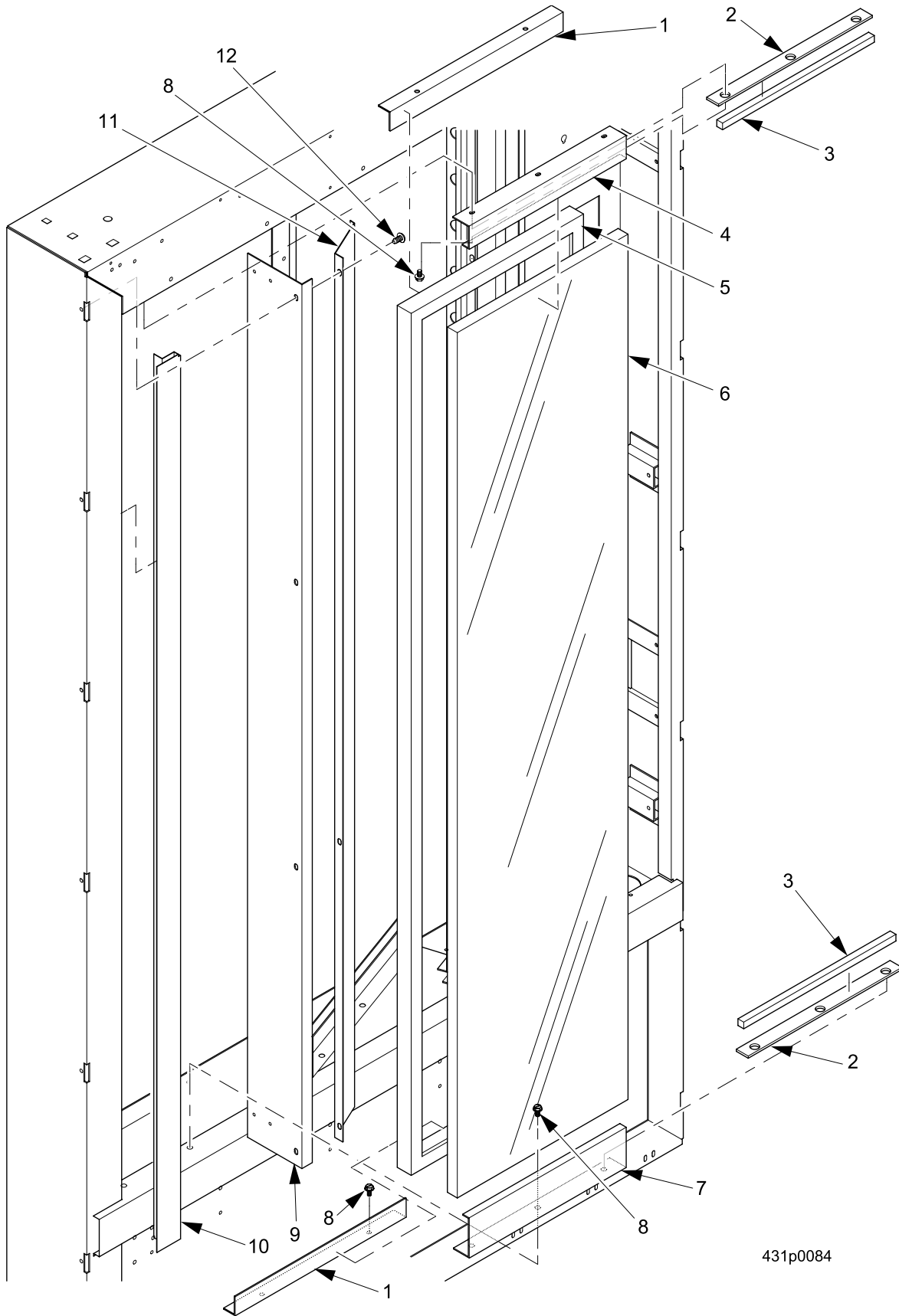

FIGURE 6: MISCELLANEOUS DOOR (PART 4 OF 4)

TABLE 6: MISCELLANEOUS DOOR (PART 4 OF 4)

INDEX	PART NUMBER	DESCRIPTION	QTY
1	4302143	CHANNEL - SPRINGS	1
2	4302118	STIFFENER - GUIDE - TOP	1
3	4312127	DOOR ASSEMBLY - VEND	9
4	2222110	T BOLT - TRIM	26
5	4302161	STIFFENER - DOOR GUIDE	9
	4302117	STIFFENER - DOOR GUIDE	
6	9900081	NUT #8 - 32 KEPS ZINC PLATE	--
7	4302222	ANGLE - MECHANISM SUPPORT	1
	4302401	ANGLE - MECHANISM SUPPORT (BLACK)	
8	4312215	SCREW - #8 - 18 X 1 1/4 RHP TAPPIN	--
9	4302145	SPRING - DOOR	9
10	4302113	HOUSING - SPRING	10
11	9900106	SCREW #8-32 X 3/8 ACORN HEX HD S/TA	--
12	4302407	STOP - VEND DOOR - ADJUSTABLE	9
13	4302105	BAR - DOOR GUIDE	10
14	4302269	GUIDE - DOOR	10
--	4312124	TAPE FLOCKED - .25" WIDE	48"



431p0084

FIGURE 7: GLASS ASSEMBLY

TABLE 7: GLASS ASSEMBLY

INDEX	PART NUMBER	DESCRIPTION	QTY
1	4312083	ANGLE - GLASS - .62 - BLACK	2
2	4312123	SPACER - GLASS	1
3	4302206	GASKET - GLASS CONTAINER	1
4	4302078	RETAINER - GLASS - TOP	1
5	4312081	GASKET - DOOR GLASS - .62	1
6	4312264	GLASS ASSEMBLY - INSULATED - 5/8	1
7	4302079	RETAINER - GLASS - BOTTOM	1
8	1451097	SCREW - #8-32X.31 HEX HD.TF BLACK	--
9	4312130	BRACKET - LIGHT - WHITE	1
10	4302119	TRIM - DOOR - LEFT	1
11	4312132	SHIELD - LIGHT - WHITE	1
12	4312217	SCREW #8-32 X.50 THS S/TAPPING	--

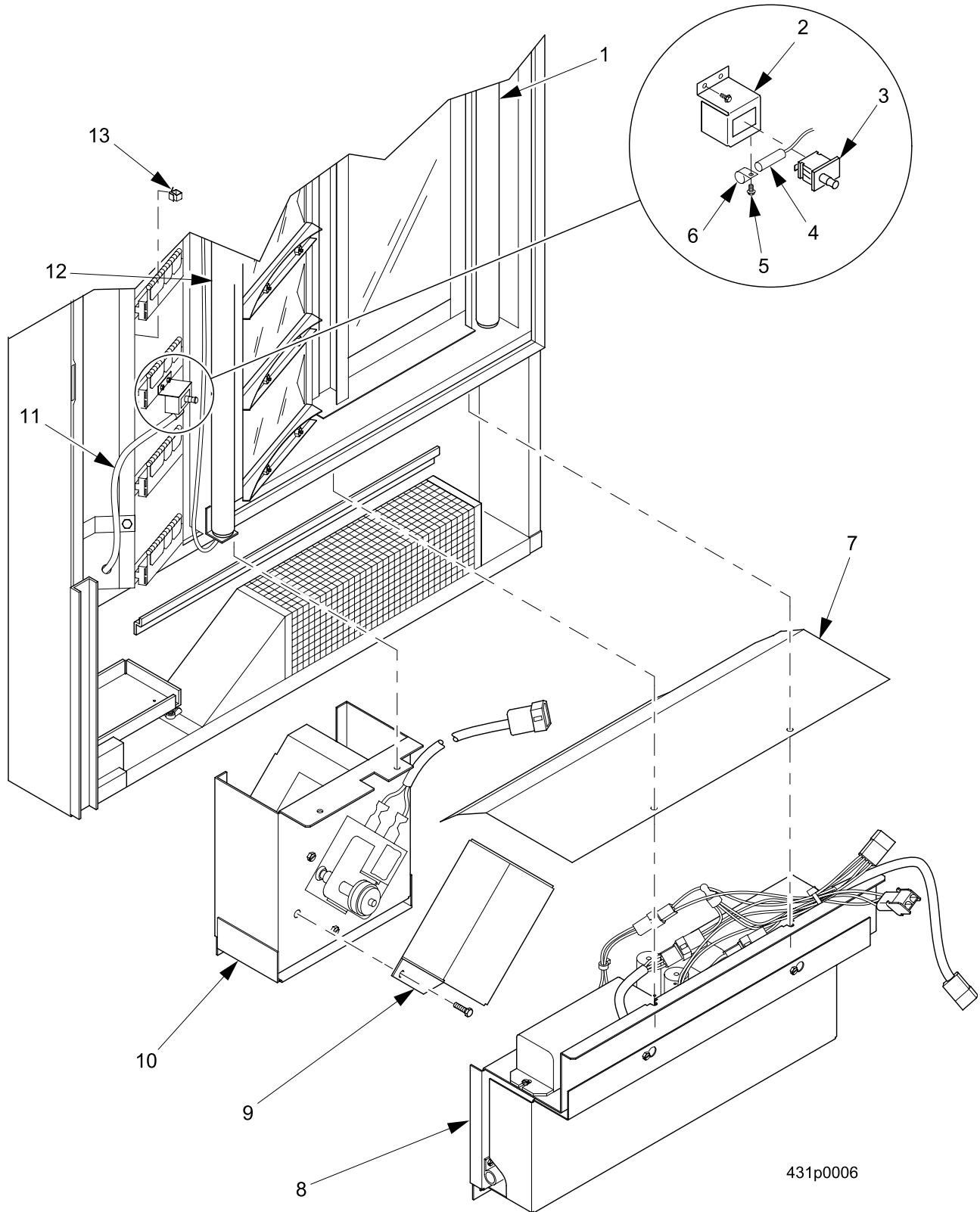
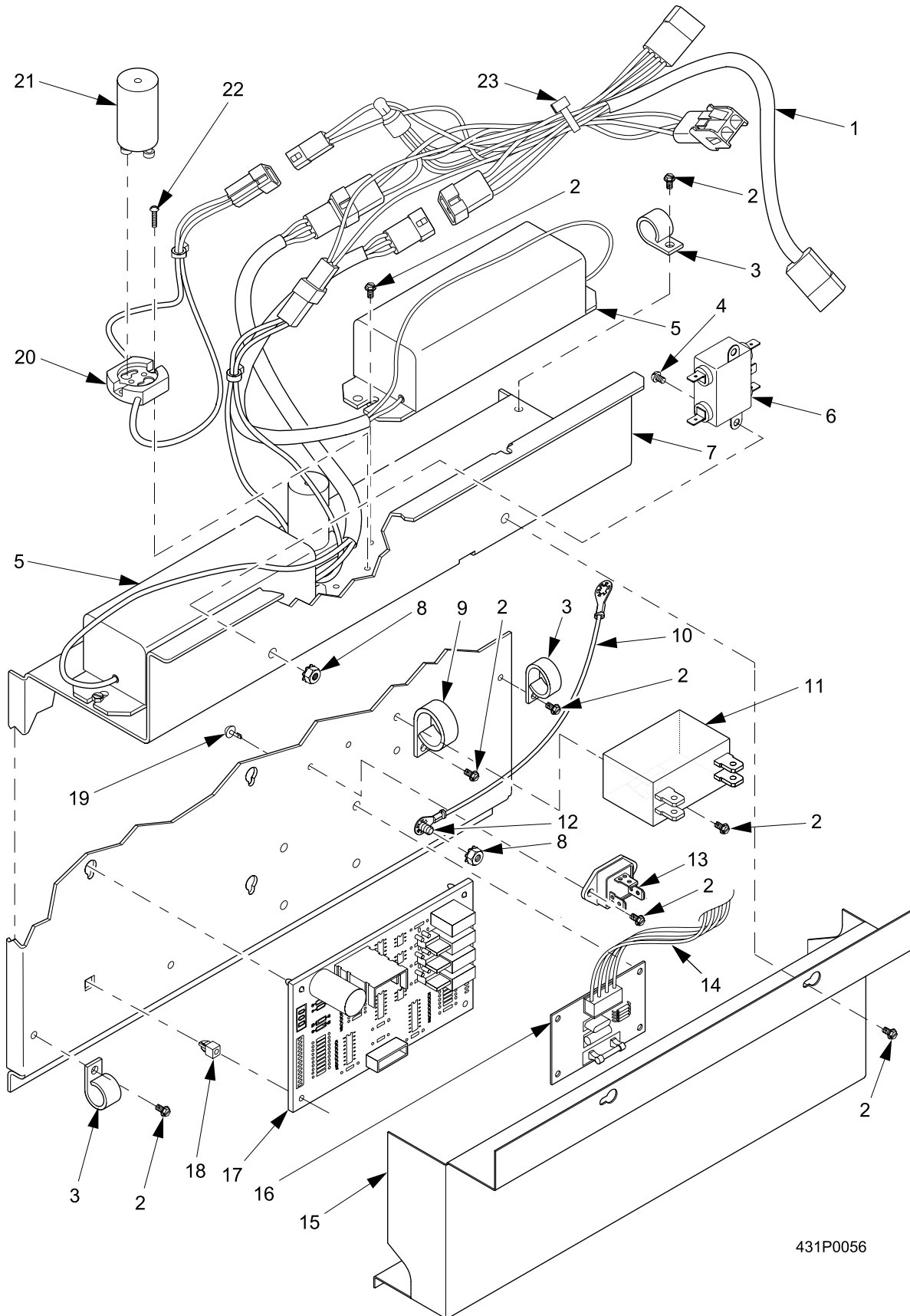

FIGURE 8: LOWER DOOR ASSEMBLIES

TABLE 8: LOWER DOOR ASSEMBLIES

INDEX	PART NUMBER	DESCRIPTION	QTY
1	4312072	FLUORESCENT LIGHT BRACKET ASSEMBLY	1
	4312078	FLUORESCENT LIGHT BRACKET ASSEMBLY - BLACK	
2	4312009	BRACKET - TURRET SWITCH	1
3	1236050	SWITCH - INTERLOCK	1
4	9987852	PROBE - TEMPERATURE SENSOR	1
5	1451097	SCREW - #8 - 32X.31 HEX HD.TF - BLACK.	--
6	2342315	CLIP - WIRE HARNESS	1
7	4312272	SHIELD - BALLAST	1
8	4311250	ELECTRICAL ASSEMBLY - LOWER DOOR	1
9	4312055	COVER - BLOWER MOTOR	1
9	4312010	DUCT - BLOWER ASSEMBLY	1
10	4312210	BLOWER ASSEMBLY - DUCT - J120V (SEE TABLE 29 FOR DETAILS)	1
	4312050	BLOWER ASSEMBLY - DUCT - 220V (SEE TABLE 29 FOR DETAILS)	
11	4319027	HARNESS - 24V - TEMPERATURE & SWITCH	1
12	4302187X	MECHANISM COVER & LIGHT BRACKET (WHITE)	1
	4302398X	MECHANISM COVER & LIGHT BRACKET (BLACK)	
13	1402100	CLIP - WIRE	5



431P0056

FIGURE 9: LOWER DOOR ELECTRICAL ASSEMBLY

TABLE 9: LOWER DOOR ELECTRICAL ASSEMBLY

INDEX	PART NUMBER	DESCRIPTION	QTY
--	4311250	ELECTRICAL ASSEMBLY - LOWER DOOR - 115V	--
	4311139	ELECTRICAL ASSEMBLY - LOWER DOOR - 230V	
1	4319024	HARNESS - CABINET AC	1
2	9900106	SCREW #8-32 X 3/8 ACORN HEX HD S/TA	7
3	6231035	HARNESS CLIP - .750	2
4	1211110	8-32X1/4 RHS MACH SCR ZP	2
5	4241135	BALLAST ASSEMBLY - 40W - 115V	1
	4312008	BALLAST ASSEMBLY - 40W - 230V	
6	9989100	INTERFERENCE FILTER	1
7	4312017	CHASSIS - CONTROL	1
8	9900081	NUT #8-32 KEPS ZINC PLATE	2
9	4305043	HARNESS CLIP - 1.00	1
10	9984094	WIRE - GROUND - 14"	1
11	9988210	CAPACITOR - MOTOR RUN - 10UF	1
	9988211	CAPACITOR - MOTOR RUN - 2.5UF	
12	3157060	SCREW - #8-32 X .31 HEX W/ HD. SLOTTED - T/F-ZINC PL	2
13	9983778	TRIAC - 35A-600V	1
14	4319010	HARNESS - POWER TO COIN HANDLING	1
15	4312065	COVER - CONTROL CHASSIS	1
16	9989659	PCB ASSEMBLY - DUMB MECH POWER SUPPLY (OPTIONAL) INCLUDES 1 AMP FUSE (5202048)	1
17	4316024	PCB ASSEMBLY - SHOPPER INTERFACE	1
18	1571034	STANDOFF - PCB - 3/8 SCREW MOUNT	1
19	1571035	STANDOFF - PCB - 3/8 SNAP LOCK	1
20	4319008	STARTER SOCKET ASSEMBLY	1
21	4031150	STARTER FS-4 FLUORESCENT LAMP	1
22	1211110	8-32X1/4 RHS MACHINE SCREW ZP	2
23	4042121	WIRE TIE - #PLT1M-M20	1

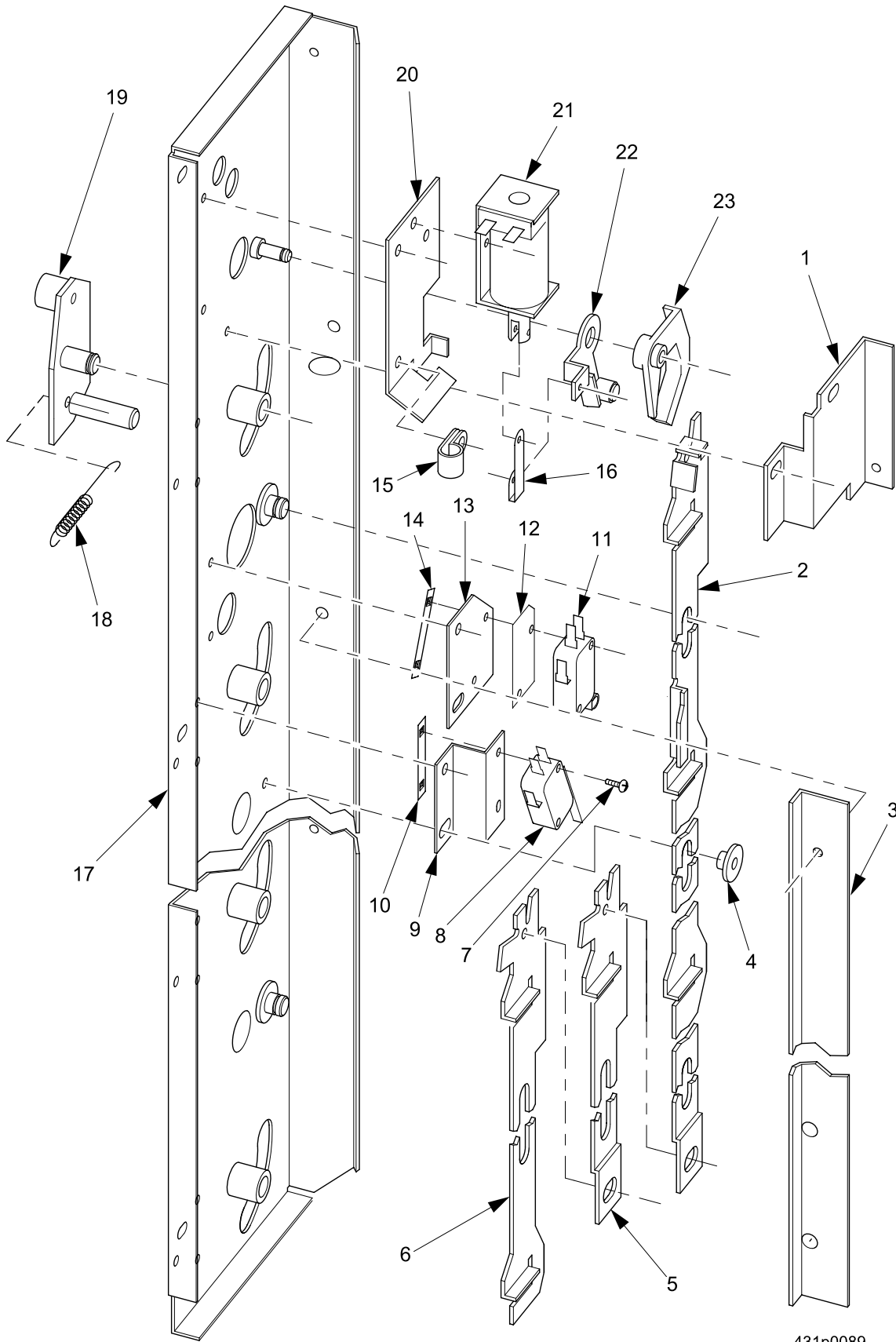

431p0089

FIGURE 10: LOCKBAR AND PANEL MECHANISM ASSEMBLY

TABLE 10: LOCKBAR AND PANEL MECHANISM ASSEMBLY

INDEX	PART NUMBER	DESCRIPTION	QTY
--	4302327	SOLENOID ASSEMBLY	1
1	4302224	COVER - PAWL	1
2	4302345	LOCKBAR - UPPER	1
3	4302223	ANGLE - LOCK BAR	1
4	4302348	RETAINER - LOCK BAR	2
5	4302324	LOCK BAR CENTER ASSEMBLY	1
6	4302320	LOCKBAR LOWER ASSEMBLY	1
7	4312216	SCREW - #4-40 X 5/8 R.H.P	--
8	9984633	SWITCH - LEVER	1
9	4302315	BRACKET - SWITCH	1
10	4302316	FASTENER - TWIN TYPE	1
11	9984637	SWITCH - LEVER	1
12	6112042	INSULATOR SWITCH	1
13	4302318	PLATE - SWITCH	1
14	4302316	FASTENER - TWIN TYPE	1
15	2302227	CABLE CLAMP RICHCO#N6	--
16	4076510	LINK - SOLENOID	1
17	4302350	PANEL MECHANISM ASSEMBLY	1
18	4312243	SPRING - LOCKOUT ARM	9
19	4302360	ARM LOCKOUT ASSEMBLY	9
20	4302329	PLATE - SOLENOID	1
21	4252029	SOLENOID - 24 VDC	1
22	4302332	PAWL ASSEMBLY	1
23	4302338	LEVER - ANTI CHEAT	1

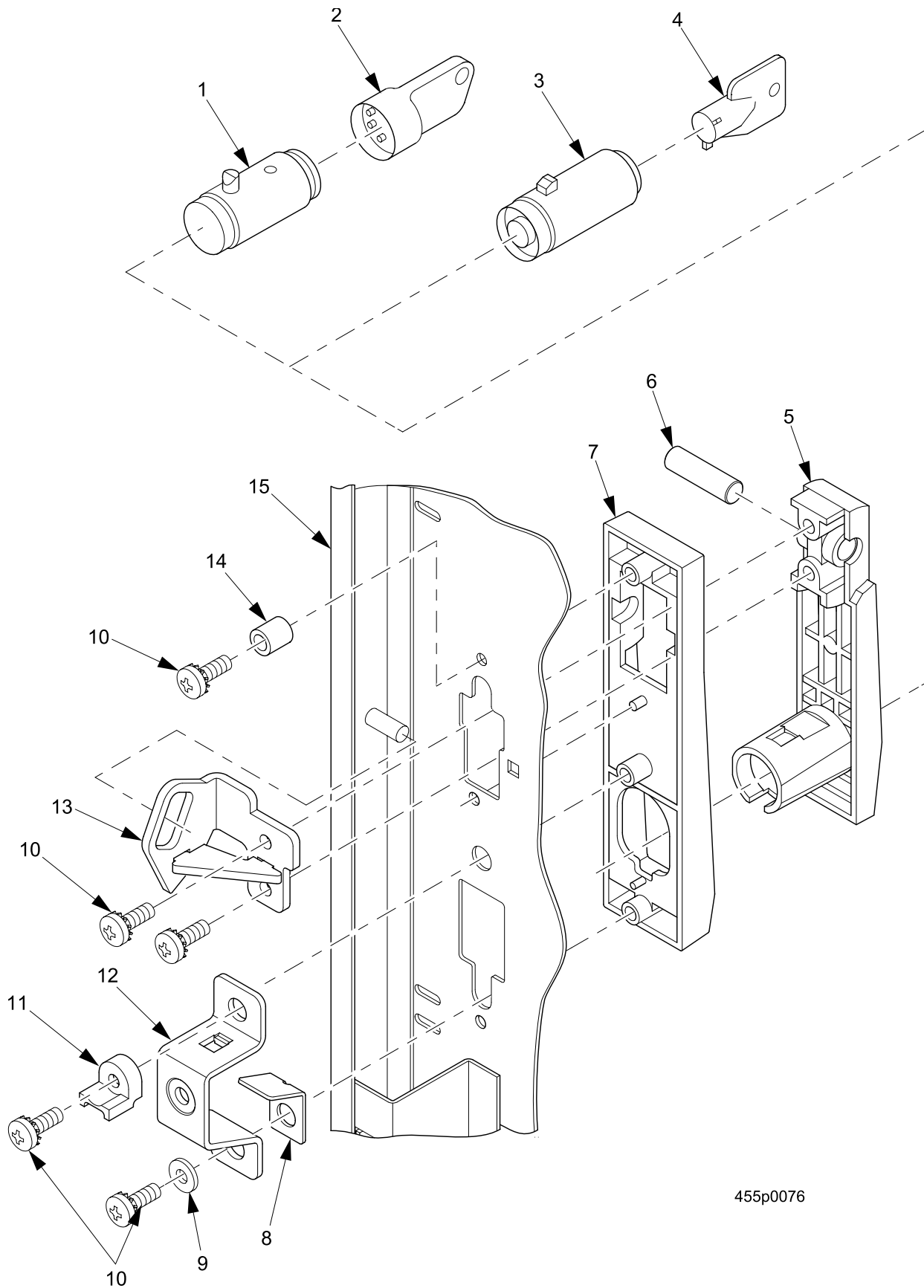

455p0076

FIGURE 11: DOOR LOCK AND HANDLE ASSEMBLY

TABLE 11: DOOR LOCK AND HANDLE ASSEMBLY

INDEX	PART NUMBER	DESCRIPTION	QTY
1	3112163	CYLINDER - VAN LOCK #4275	OPT.
2	3112164	KEY - VAN LOCK #K5-STD. COMBINATION	--
3	9992400	LOCK CYLINDER #4355-19-A	OPT.
4	--	KEY	OPT
5	1172190	LEVER LOCK	1
6	1302291	PIVOT - LEVER - LOCK	1
7	1172191	BASE LEVER LOCK	1
8	1302290	LATCH - LOCK - LOWER	1
9	6131066	WASHER 5/8X.265X.048 ZINC/YEL	2
10	9900170	SCREW - #10-32 X 1/2" PHIL.PAN HD	
11	1302326	SHIELD - LATCH	1
12	1302324	CATCH - DOOR LATCH	1
13	2272052	ACTUATOR ASSEMBLY - LOCK BAR	1
14	1302289	SPACER CUP	1
15	--	MONETARY DOOR	REF.

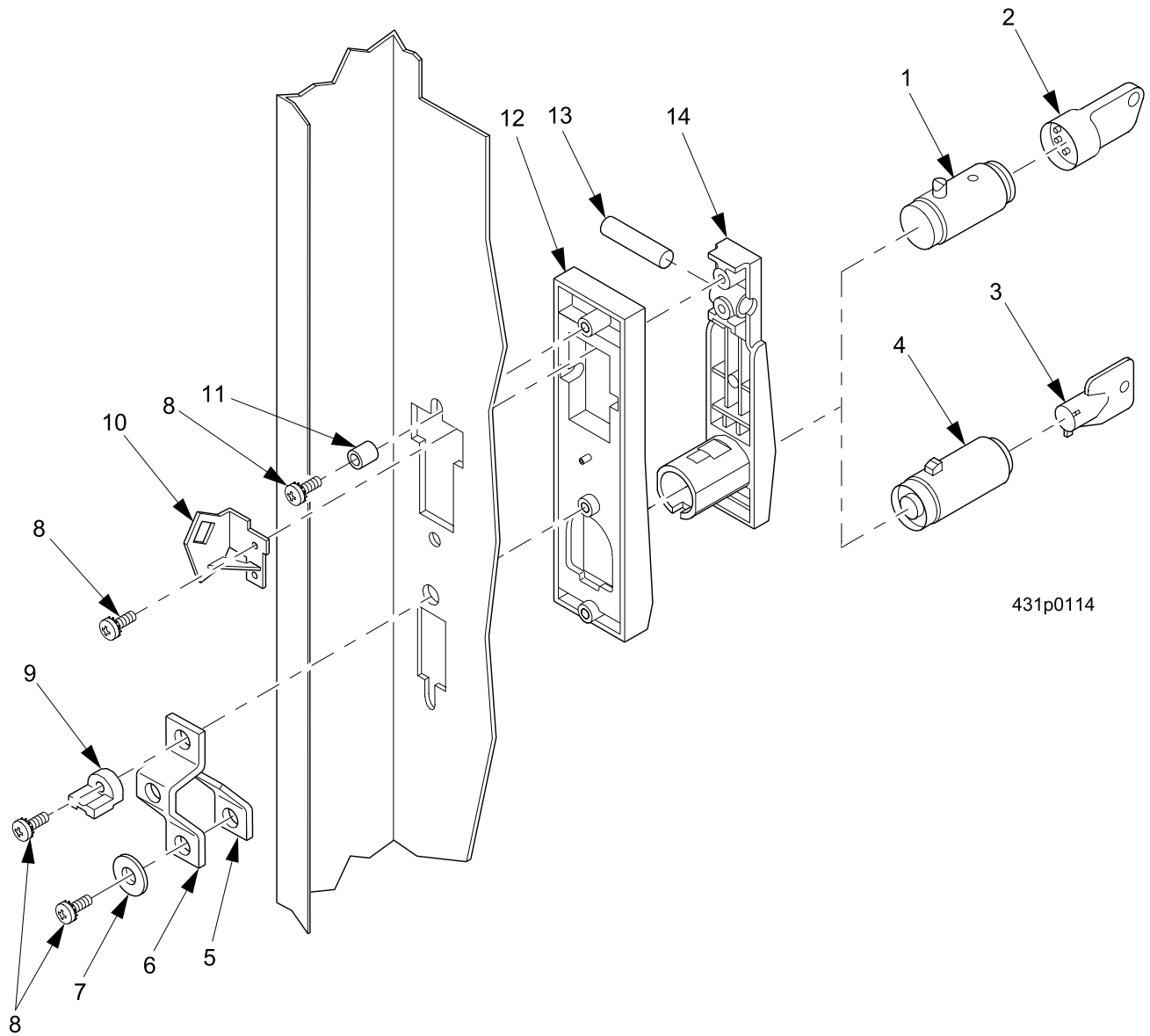
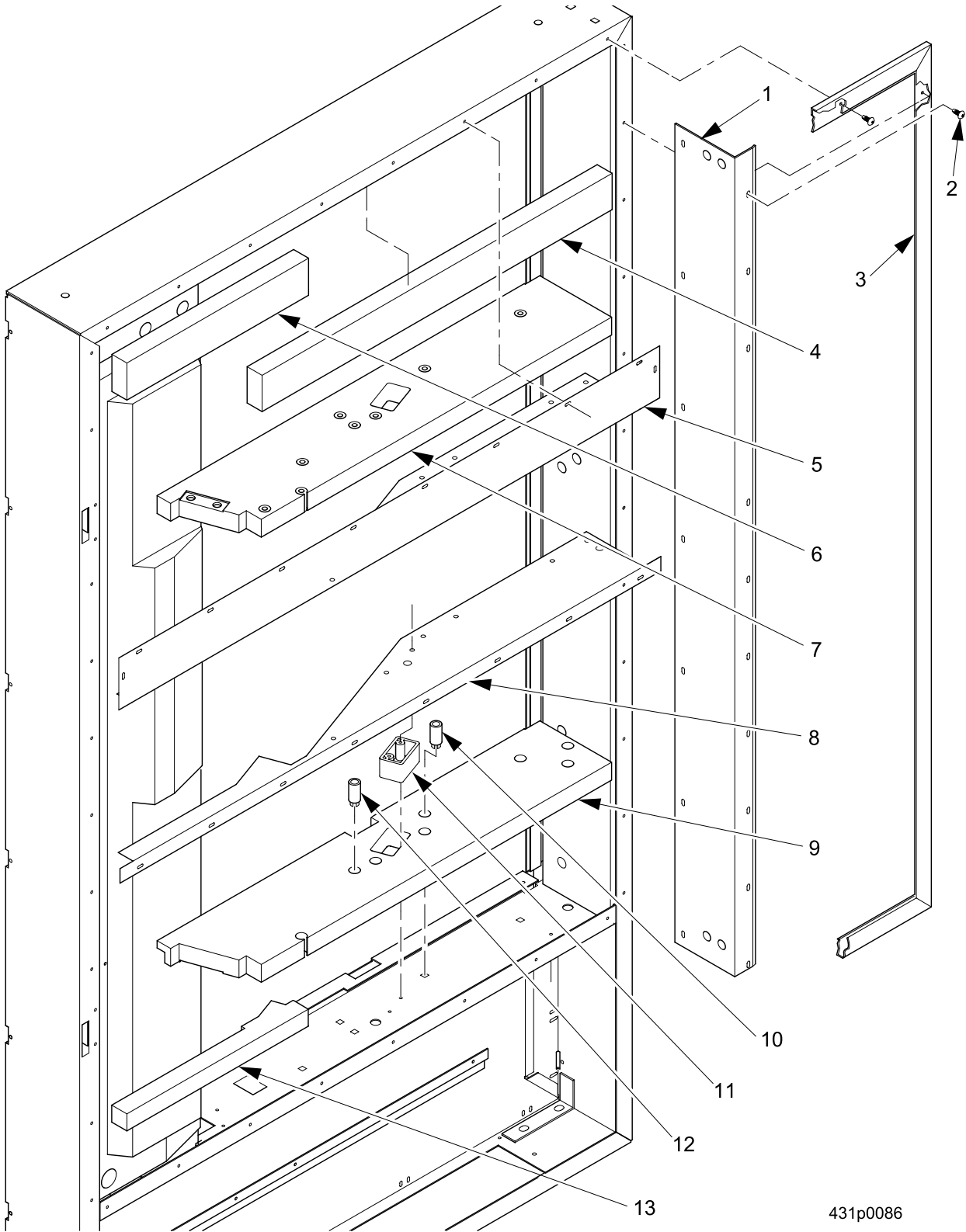

FIGURE 12: LIFT HANDLE LOCK ASSEMBLY

TABLE 12: LIFT HANDLE LOCK ASSEMBLY

INDEX	PART NUMBER	DESCRIPTION	QTY
1	3112163	CYLINDER - VAN LOCK #4275	1
2	3112164	KEY - VAN LOCK #K5 - STD. COMBINATION	1
3	9994000	GENERIC KEY	1
4	9992400	FLEX ACE LK CYL #4355-19-A KB	1
5	1302290	LATCH LOCK - LOWER	1
6	1302324	CATCH - DOOR LATCH	1
7	6131066	WASHER 5/8X.265X.048 ZINC/YEL	2
8	9900170	SCREW - #10-32 X 1/2"PHIL.PAN HD W/LKW	5
9	1302326	SHIELD - LATCH	1
10	2272052	ACTUATOR ASSEMBLY - LOCK BAR	1
11	1302289	SPACER CUP	1
12	1172191	BASE LEVER - LOCK	1
13	1302291	PIVOT - LEVER - LOCK	1
14	8905012	LEVER - LOCK - BLACK	1
	1172190	LEVER - LOCK	



431p0086

FIGURE 13: DOOR INSULATION (PART 1 OF 2)

TABLE 13: DOOR INSULATION (PART 1 OF 2)

INDEX	PART NUMBER	DESCRIPTION	QTY
1	4312208	LINER - DOOR - LEFT - WHITE	1
	4312209	LINER - DOOR - LEFT - BLACK	
2	9900156	SCREW #8-32 X 1/2 RHS S/T	--
3	4312207	GASKET - DOOR	1
	3122154	GASKET - DOOR	
4	4312219	INSULATION 1.01 DOOR TOP - LEFT	1
5	4302028	LINER - DOOR - TOP	2
	4302384	LINER - DOOR - TOP (BLACK)	
6	4312220	INSULATION 1.01 DOOR TOP - RIGHT	1
7	4312223	INSULATION 1.04 DOOR - TOP	1
8	4302029	LINER - DOOR - BOTTOM	1
	4302385	LINER - DOOR - BOTTOM (BLACK)	
9	4312222	INSULATION 1.04 DOOR - BOTTOM	1
10	9989649	SPACER - PLASTIC - .50 DIA.X1.25LG	--
11	4302036	SUPPORT - CENTER POST	2
12	4241160	SPACER - LINER	7
13	4312221	INSULATION 0.99 DOOR FILLER	2

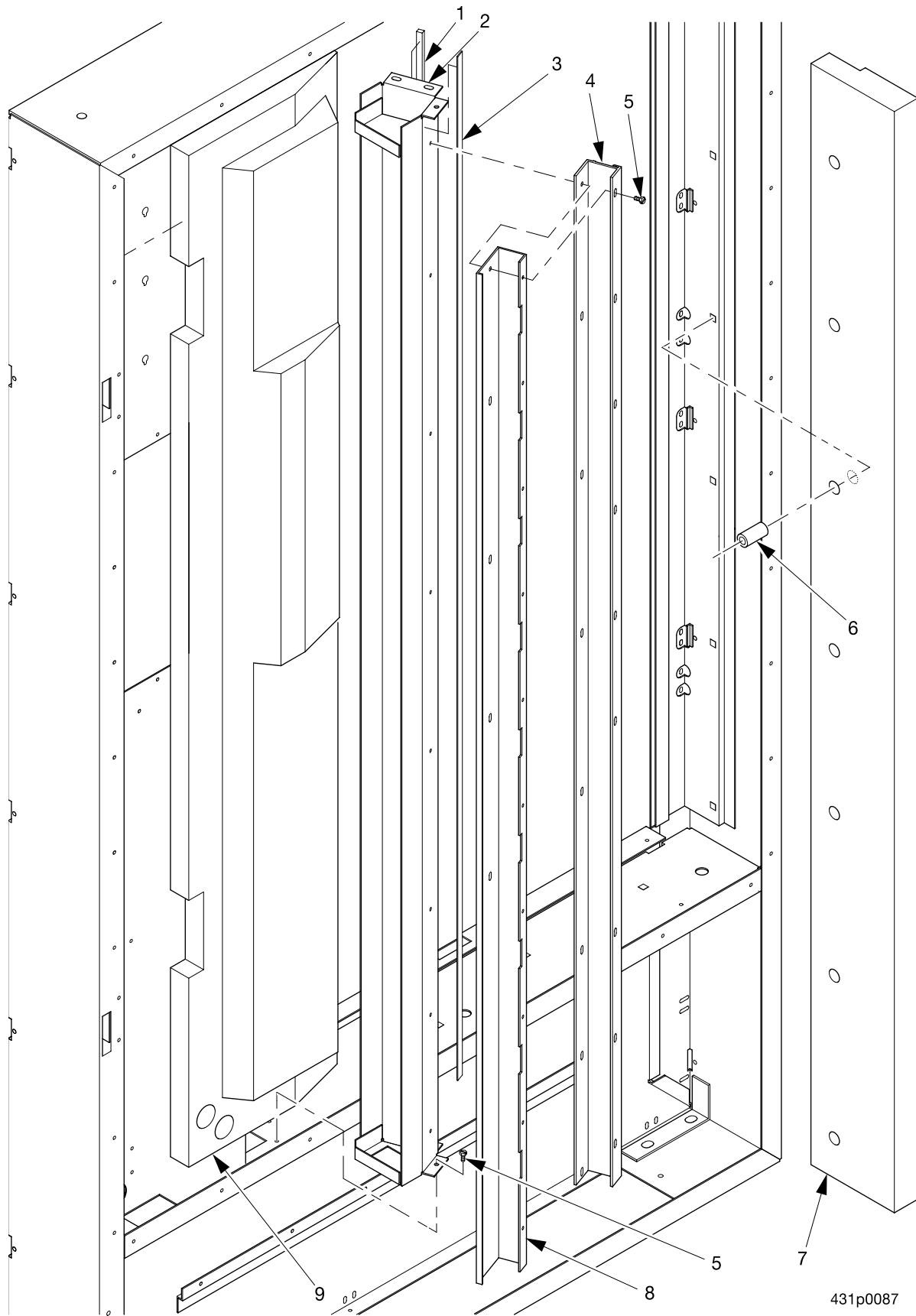

431p0087

FIGURE 14: DOOR INSULATION (PART 2 OF 2)

TABLE 14: DOOR INSULATION (PART 2 OF 2)

INDEX	PART NUMBER	DESCRIPTION	QTY
1	4302214	SEAL - .50 X .75	A/R
2	4312145	DUCT ASSEMBLY - VEND DOOR	1
3	4302213	FOAM TAPE - 47.50 LONG	A/R
4	4302035	COVER - DOOR CHANNEL	1
5	9900106	SCREW #8-32 X 3/8 ACORN HEX HD S/TA	--
6	9989649	SPACER - PLASTIC - .50 DIA.X1.25LG	--
7	4302098	INSULATION - DOOR - LEFT	1
8	4302143	CHANNEL - SPRINGS	1
9	4302097	INSULATION - DOOR - RIGHT	1

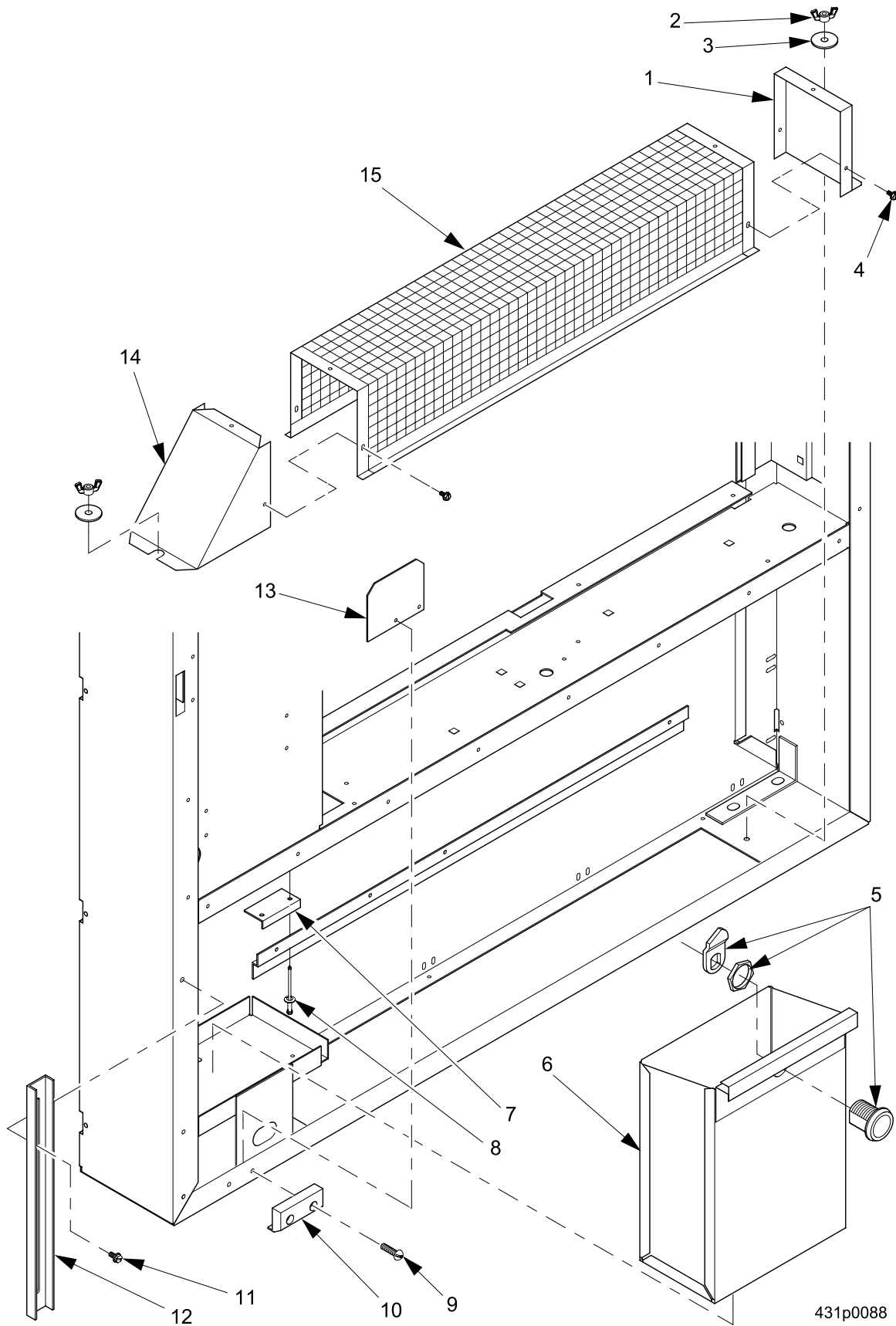

431p0088

FIGURE 15: SCREEN ASSEMBLY

TABLE 15: SCREEN ASSEMBLY

INDEX	PART NUMBER	DESCRIPTION	QTY
--	4302061	SUBASSEMBLY - FRONT SCREEN (NON-DEBITEK UNITS)	--
	4312056	DOOR SCREEN ASSEMBLY - DEBITEK	
1	4041057	END CAP SCREEN FRONT	2
	4312060	END CAP - DOOR SCREEN - LEFT (USED WITH DEBITEK ONLY)	1
2	9900039	WING NUT #10-32 SELF - LOCKING	--
3	1122521	BUSHING - LOCK CAM	--
4	1451097	SCREW - #8-32X.31 HEX HD.TF BLACK.	6
5	1101906	MONEY BOX LOCK - #1801, KA NV407 CHICAGO LOCK #1801	1
6	4302408	BOX ASSEMBLY - MONEY	1
7	4302022	ANGLE - MONEY BOX LOCK	1
8	4311236	RIVET - POP - ALUM./ALUM.-.156 DIA	--
9	9900204	SCREW #8-32 X 5/8 RHS S/T	--
10	4302191	GLIDE - DOOR	1
11	1141046	SCREW - #10-32X3/8 ACORN HEX W/H	--
12	4302237	DOOR SUPPORT CHANNEL	1
13	4312063	PLATE - DOOR SWITCH ACTUATOR	1
14	4302163	END CAP - SCREEN FRONT	1
	4312061	END CAP - DOOR SCREEN - RIGHT (USED WITH DEBITEK ONLY)	
15	4302144	SCREEN - FRONT	1
	4312057	SCREEN - DOOR (USED WITH DEBITEK ONLY)	

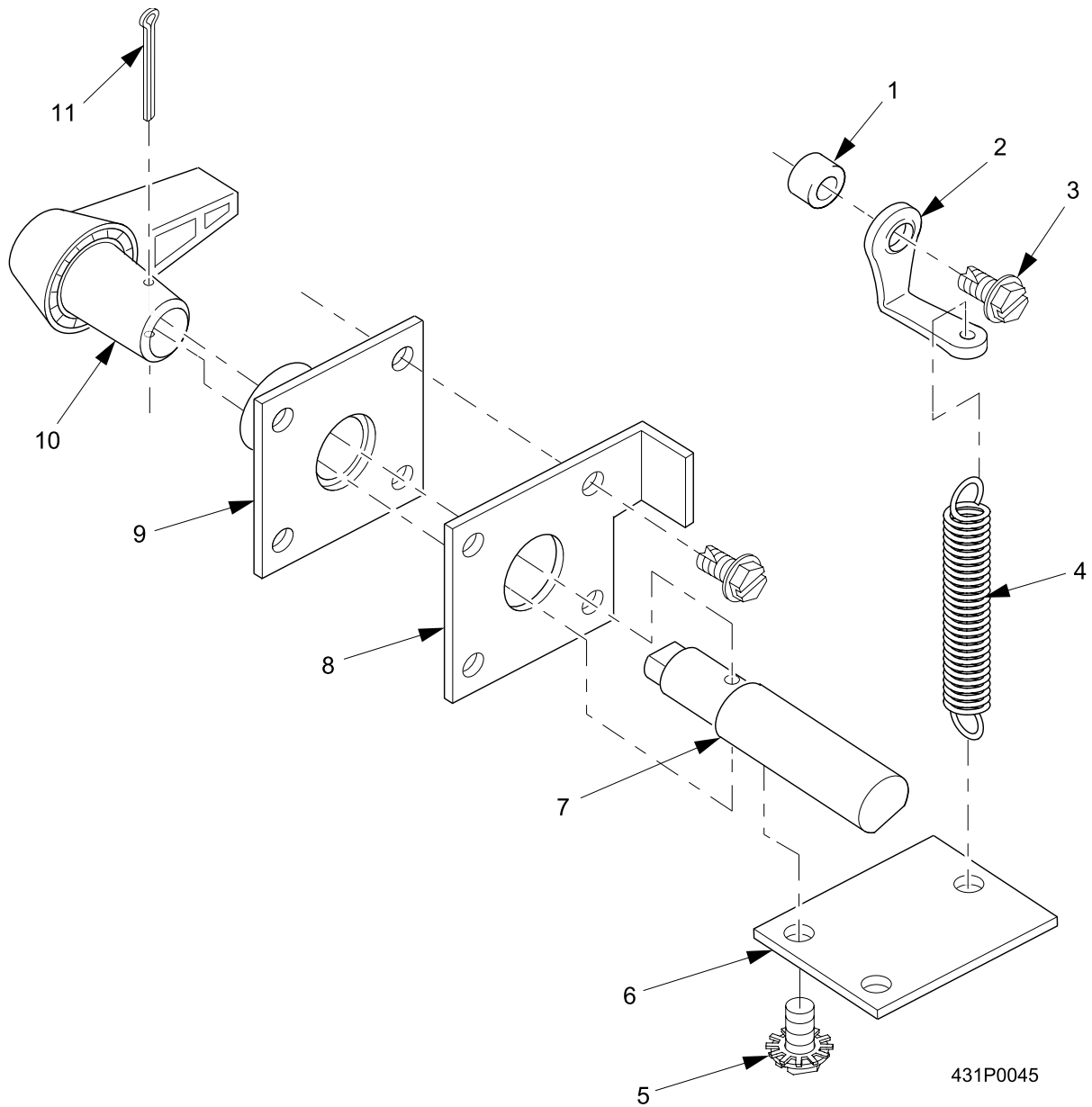
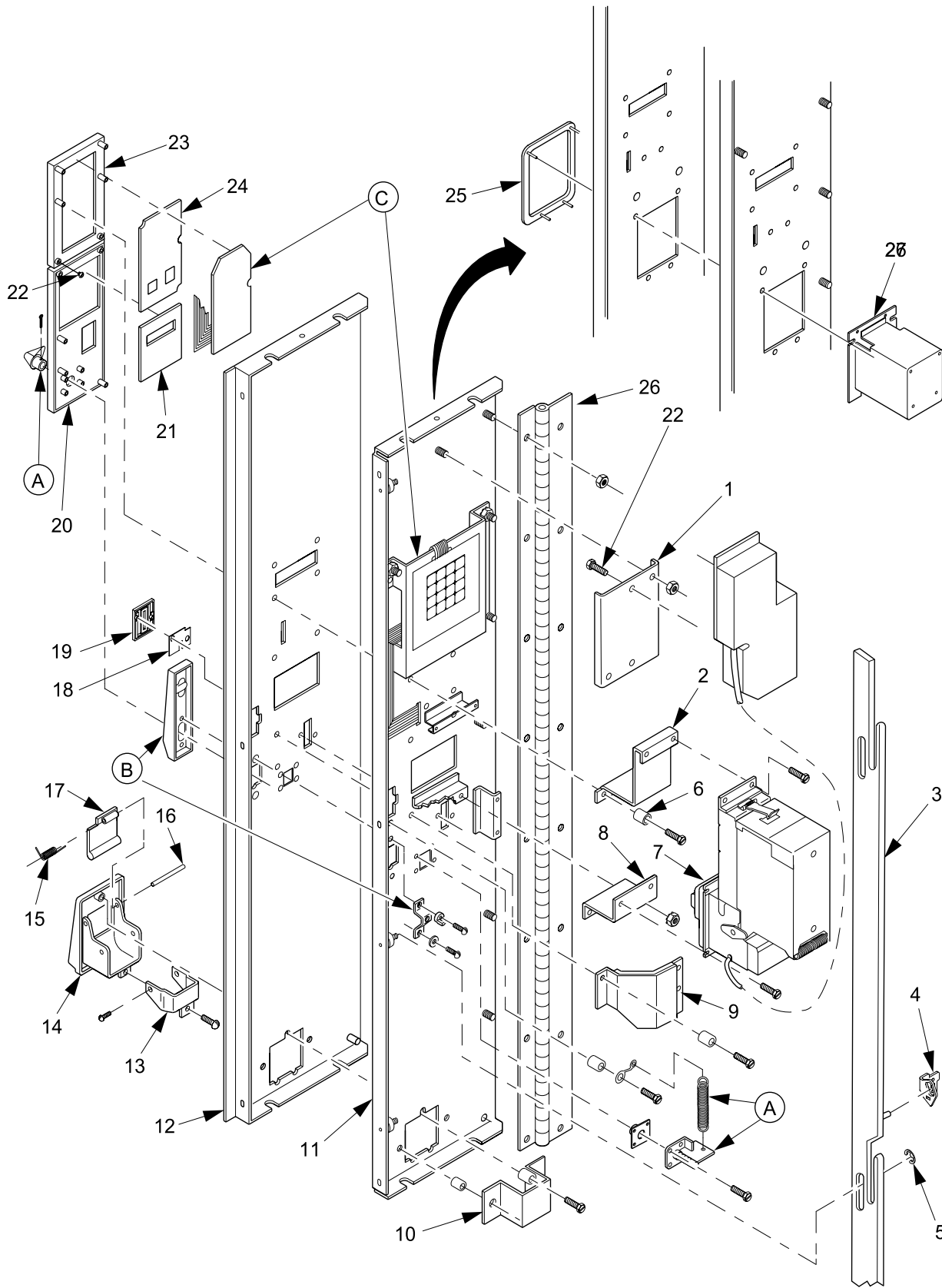

FIGURE 16: SCAVENGER ASSEMBLY

TABLE 16: SCAVENGER ASSEMBLY

INDEX	PART NUMBER	DESCRIPTION	QTY
1	2302053	SPACER - CUP	1
2	4241235	LOCKING - TERMINAL - LUG	1
3	9900106	SCREW #8-32 X 3/8 ACORN HEX HD S/TA	--
4	4076515	SPRING COMMON BAR	1
5	6234295	SCREW - #8-32X.38 HHS W/LW	--
6	4305062	LEVER - COIN RETURN	1
7	4305050	SHAFT - COIN RETURN	1
8	4305026	STOP - COIN RETURN LEVER	1
9	1402014	BEARING - SCAVENGER	1
10	1452191	HANDLE - SCAVENGER	1
11	9900098	COTTER PIN 3/32 X 3/4 IN	1



431p0067

FIGURE 17: MONETARY DOOR

TABLE 17: MONETARY DOOR

INDEX	PART NUMBER	DESCRIPTION	QTY
1	4305131	BRACKET - MOUNTING - VALIDATOR CONTROLLER	1
2	4315014	BRACKET - UPPER - COINCO VALIDATOR	OPT
	4315012	BRACKET - UPPER - MARS VALIDATOR	
	4305016	BRACKET - UPPER - MAKA VALIDATOR	
3	4305027	LOCKBAR ASSEMBLY	1
4	2272052	ACTUATOR ASSEMBLY - LOCK BAR	1
5	9900425	RETAINING RING - REINF. "E-TYPE" .250	4
6	2302053	SPACER - CUP	12
7	--	VALIDATOR (SEE TABLE 19 FOR DETAILS)	OPT
8	4315015	BRACKET - LOWER - COINCO VALIDATOR	OPT
	4315013	BRACKET - LOWER - MARS VALIDATOR	
	4315018	BRACKET - LOWER - MAKA VALIDATOR	
9	4305048X	COINCHUTE - BACK & COVER ASSEMBLY	1
10	4305008	BRACKET-COIN CHUTE MTG.	OPT
11	4315030	WELD ASSEMBLY - DOOR - MONETARY	1
	4315041	WELD ASSEMBLY - DOOR - MONETARY - DEBITEK - STANDARD	
12	4315032	TRIM PANEL - MONETARY DOOR	--
13	1272044	PLATE - RECEPTACLE - 2 ICE	1
14	1272131	COIN RECEPTACLE	1
15	1212117	SPRING - COIN RETURN DOOR	1
16	1272039	PIN - GATE	1
17	1272132	SPRING - COIN RECEPTACLE	1
18	1472222	COIN BLOCK (USA)	1
19	1472223	COIN INSERT	1
20	4305114	CASTING - SCAVENGER - CARD READER CPT - STANDARD	1
	4315070	CASTING - SCAVENGER - BLACK	
21	--	INSERT - INSTRUCTIONS - LOWER (SEE TABLE 20 FOR DETAILS)	1
	--	INSERT - INSTRUCTIONS - UPPER (SEE TABLE 19 FOR DETAILS)	1
22	9900106	SCREW #8-32 X 3/8 ACORN HEX HD	
23	4255026	BEZEL - PUSH BUTTON - STANDARD	1
24	4315069	BEZEL - INSTRUCTIONS PLATE - BLACK	1
25	4305105	FRAME ASSEMBLY - CARD READER CPT	OPT
26	4305011	HINGE - MONETARY DOOR	1
27	--	CARD READER (SEE TABLE 20 FOR DETAILS)	OPT
A	--	SCAVENGER ASSEMBLY (SEE TABLE 16 FOR DETAILS)	--
B	--	LIFT HANDLE LOCK ASSEMBLY (SEE TABLE 12 FOR DETAILS)	--
C	--	MONETARY DOOR ELECTRONICS ASSEMBLY (SEE TABLE 18 FOR DETAILS)	--

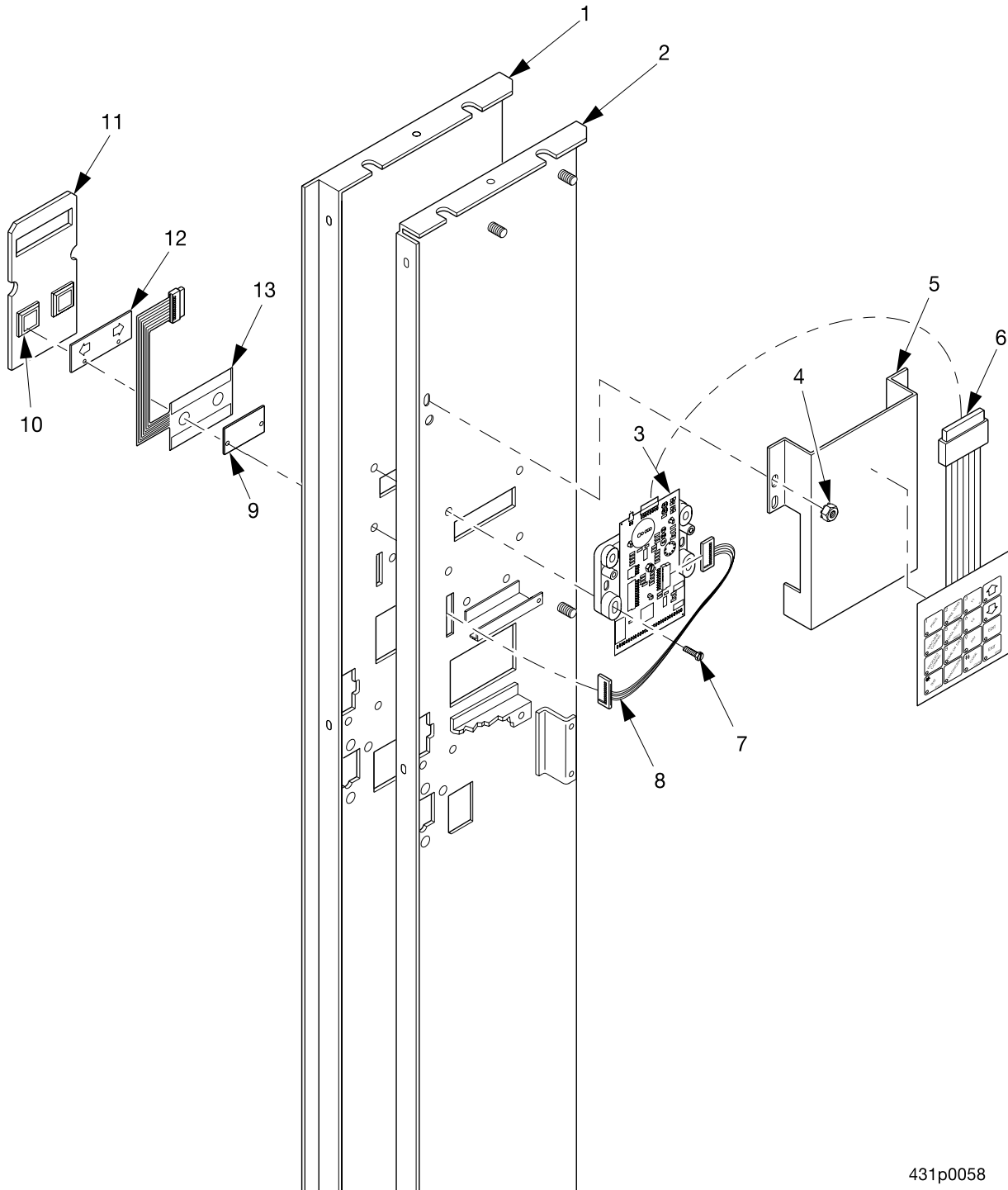

431p0058

FIGURE 18: MONETARY DOOR ELECTRONICS ASSEMBLY

TABLE 18: MONETARY DOOR ELECTRONICS ASSEMBLY

INDEX	PART NUMBER	DESCRIPTION	QTY
1	4315032	TRIM PANEL - MONETARY DOOR	1
2	4315030	DOOR WELD ASSEMBLY - MONETARY	1
3	9989823	DISPLAY W/ BRACKET ASSEMBLY	1
	9989628	PCB ASSEMBLY - DISPLAY - UNIVERSAL	
4	9900081	NUT #8-32 KEPS ZINC PLATE	--
5	1475099	BRACKET - PCB - DISPLAY	1
6	6335002X	SERVICE KEYPAD ASSEMBLY	1
	6335005	SERVICE KEYPAD ASSEMBLY - SPANISH	
7	9900203	SCREW #6-20 X 3/8 PHS T/C	--
8	1599200	HARNESS - CONTROL TO DISPLAY	1
9	4305077	DIRECTION SWITCH SHIM PLATE	1
10	1472251	LENS - PUSHBUTTON	2
11	4305071	BUTTON HOUSING ASSEMBLY	1
12	4305069	ARROW SHEET - PUSHBUTTON	1
13	4315001	DIRECTION SWITCH - MEMBRANE	1

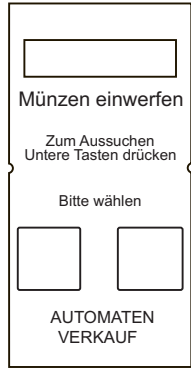

4305079
GERMANY

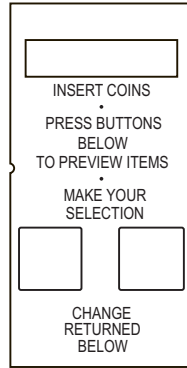

4305072
USA
UK
NEW ZEALAND
AUSTRALIA



4305147
SWEDEN

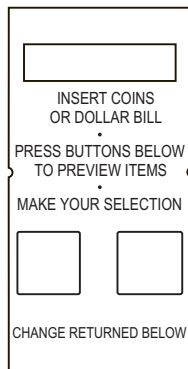

4305066
USA
NAVY
SAUDI ARABIA

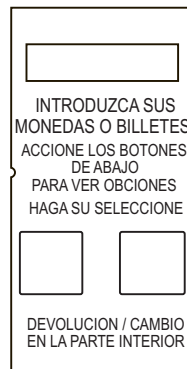

4305133
ARGENTINA

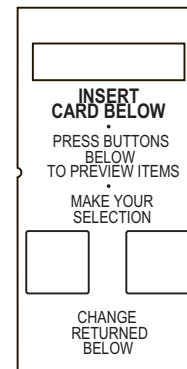

4305103
USA

431p0070

FIGURE 19: INSTRUCTION INSERTS - UPPER



1452362
COINS ONLY

USA
SAUDI ARABIA

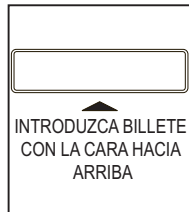

4305132
COINS & BILLS -
CBV

ARGENTINA

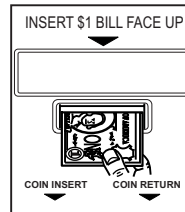

4305022
COINS & BILLS

USA
NAVY

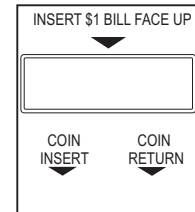

4315019
COINS & BILLS -
COINCO

USA



1052006
COINS ONLY

UK
AUSTRALIA
NEW ZEALAND

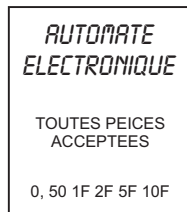

4312241
COINS ONLY

FRANCE

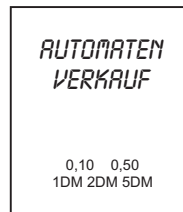

4312241
COINS ONLY

GERMANY



3172031
COINS ONLY

SWEDEN

431p0071

FIGURE 20: INSTRUCTION INSERTS - LOWER

This Page Intentionally Left Blank

TABLE 19: VALIDATOR OPTIONS

PART NUMBER	DESCRIPTION	USE HARNESS	QTY
5900272	VALIDATOR - COINCO - #BA-30-SA	1579028	1
5900194	VALIDATOR - MARS - S2000 - VN2521U3E - CNSMT	1579028	1
5900206	VALIDATOR - MARS VN2522-U3E-24 - VAC	1579032	1
5900211	VALIDATOR - MARS VN2522-U3M/230 "MDB	--	1
5900283	VALIDATOR - COINCO - MAGPRO - 32R KB	--	1
5900284	VALIDATOR - COINCO - MAGPRO - 30SA KB	--	1
5900285	VALIDATOR - COINCO - MAGPRO - 32SA KB	1579032	1
5900235	VALIDATOR - CONLUX MAK2152-11B 120V	1579028	1
5900267	VALIDATOR - CONLUX NBM3140MDB-400	1579050	1
5900206	VALIDATOR - MARS VN2522-UE3 - 24VAC	1579032	1
5900249	VALIDATOR - MARS - AE2622 U3M - MDB	--	1
5900250	VALIDATOR - MARS - AE2621 U3M - SERIAL	1579028	1

TABLE 20: CARD READER OPTIONS

PART NUMBER	DESCRIPTION	USE HARNESS	QTY
5900246	CARD READER - DEBITEK - KV1S - MDB	--	1

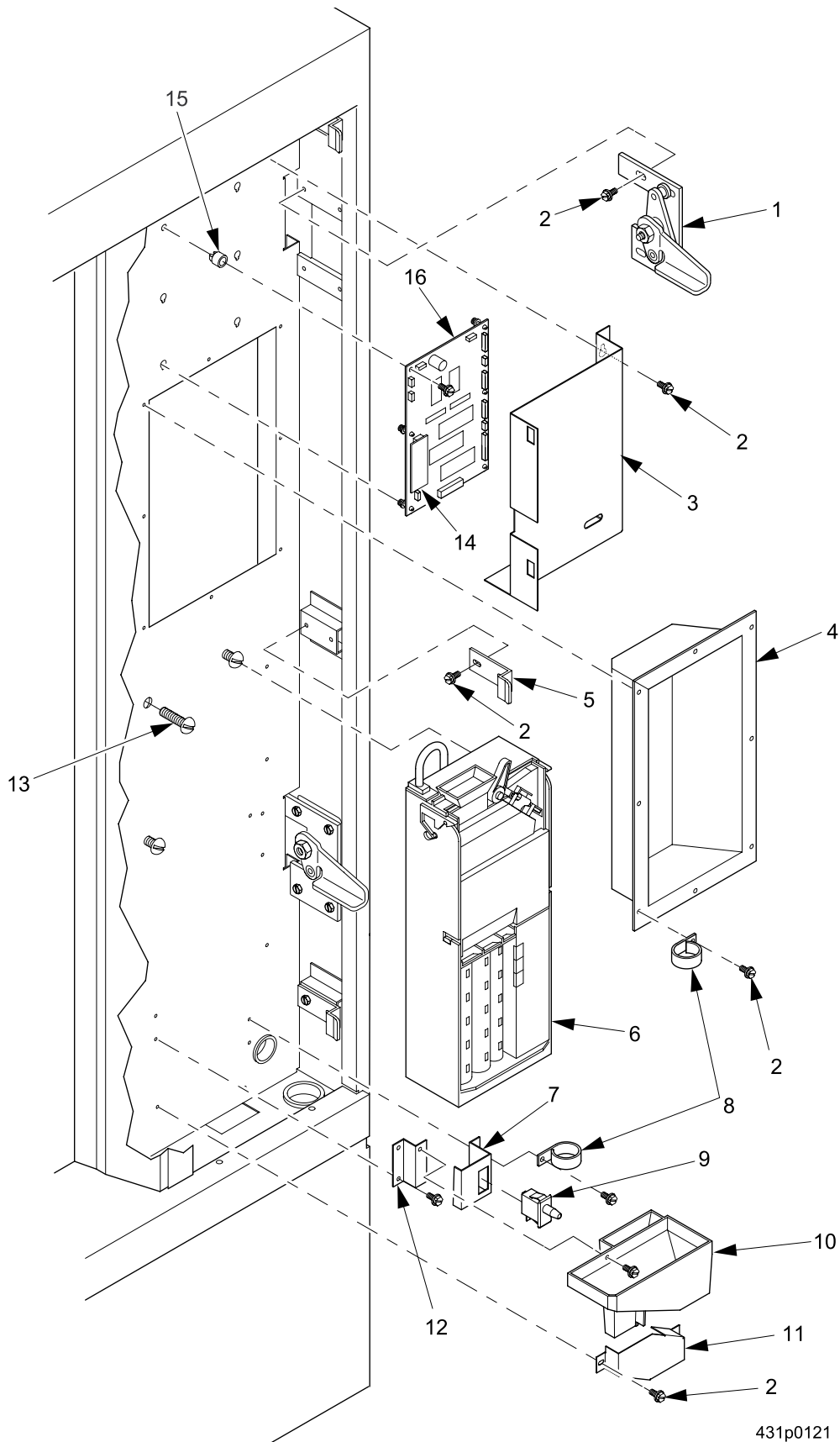

FIGURE 21: MONETARY COMPARTMENT

431p0121

TABLE 21: MONETARY COMPARTMENT

INDEX	PART NUMBER	DESCRIPTION	QTY
1	4302039	LATCHPLATE ASSEMBLY (SEE TABLE 22 FOR DETAILS)	2
2	1141046	SCREW - #10-32X3/8 ACORN HEX W/HD SEMS T/C	--
3	4315007	COVER - INTERFACE PCB	1
4	4302032	HOUSING - VALIDATOR	1
5	4302055	BAR - DOOR PANEL LATCH	3
6	--	COIN MECHANISM (SEE TABLE 21A FOR DETAILS)	OPT
7	4312218	BRACKET - MONETARY INTERLOCK	1
8	4305043	CLIP - HARNESS	7
9	6111041	SWITCH - SERVICE LIGHT	1
10	1451334	CHUTE - COIN RETURN	1
11	4302090	CHUTE - CASH BOX	1
12	4302049	BRACKET - CHUTE MOUNTING	1
13	9900106	SCREW #8-32 X 3/8 ACORN HEX HD S/TA	--
14	4316036	IC ASSEMBLY-VERSION 431.18	1
15	4241165	SPACER - LINER - .375LG X.500 DIA	1
16	4316028	MAIN CONTROLLER PCB W/E-PROM (INCLUDES FOLLOWING 2)	1
--	(SEE LABEL)	IC ASSEMBLY	1
--	9989755	PCB ASSEMBLY - MAIN CONTROLLER	1

TABLE 21A: COIN MECHANISM OPTIONS

PART NUMBER	DESCRIPTION	QTY
5900116	MARS TRC 6000 COIN UNIT	1
5900112	MARS MC5000 COIN UNIT	1
5900097	COINCO 9340L - BRC - COIN UNIT	1
6400002	MARS # TRC 6010 XV - COIN CHANGER	1
6400003	COINCO 9302LF - 24VDC - COIN CHANGER	1
5900244	COINCO USD - G701 MDB - COIN UNIT	1
5900269	COINCO USQ - G701 - MDB-4 TUBE KB	1
5900243	TRC 6512 MDB - CONSNMNT - COIN UNIT	1
5900213	COINCO - 9302 - GX - "MDB" - COIN UNIT	1
5900209	CONLUX USLZ - 001 "MDB" - COIN UNIT	1
5900279	COIN MECH - CONLUX CCM5G-4	1
5900276	COIN UNIT - MARS - VN4510 - 5/10/25/25 KB	1
5900214	COIN UNIT - MARS - VN4510 - MDB	1
5900216	COIN UNIT - MARS - VN4000 110V	1

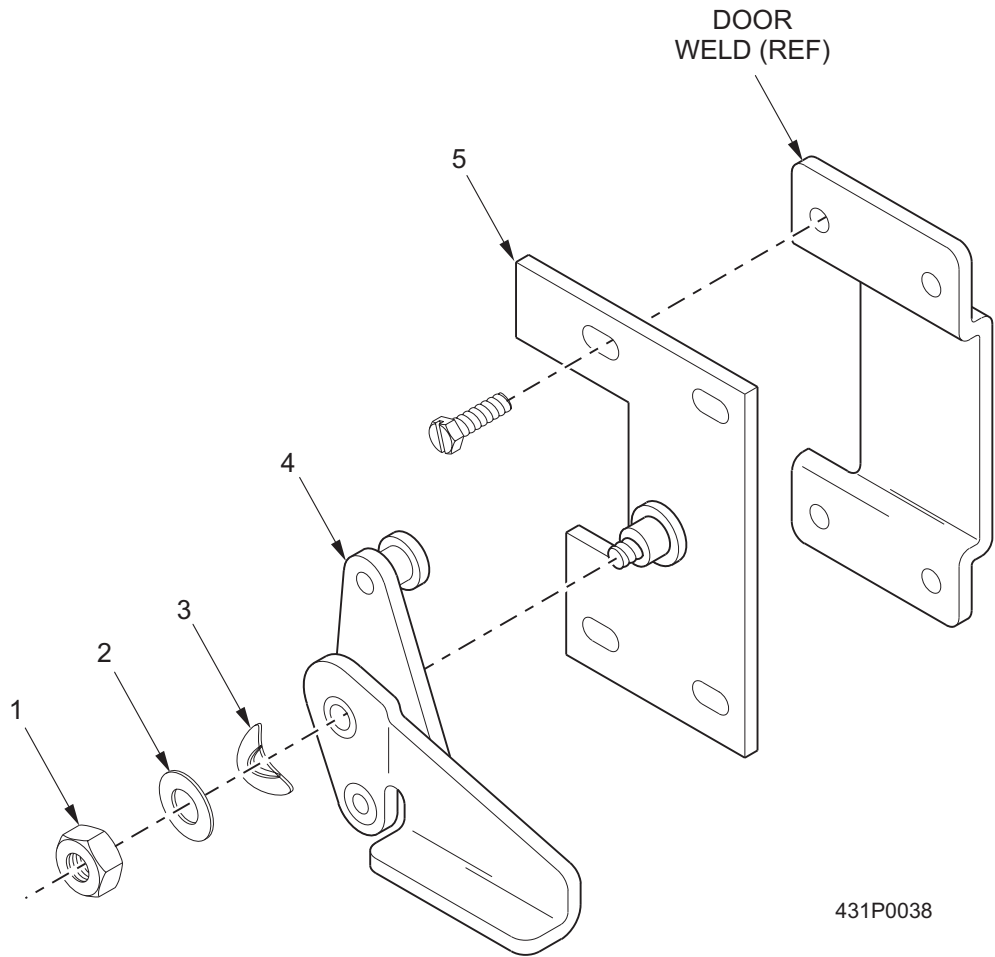

FIGURE 22: MONETARY COMPARTMENT LATCH AND PLATE ASSEMBLY

TABLE 22: MONETARY COMPARTMENT LATCH AND PLATE ASSEMBLY

INDEX	PART NUMBER	DESCRIPTION	QTY
--	4302039	LATCH & PLATE ASSEMBLY - MONETARY	REF
1	9900207	NUT #10-32 SELF - LOCKING	1
2	6138181	WASHER - PLATE	1
3	1141057	SPRING WASHER - .750 X .395 X .020	1
4	4302040	LATCH ASSEMBLY - CABINET	1
5	4302050	PLATE ASSEMBLY - CABINET LATCH MOUNTING	1

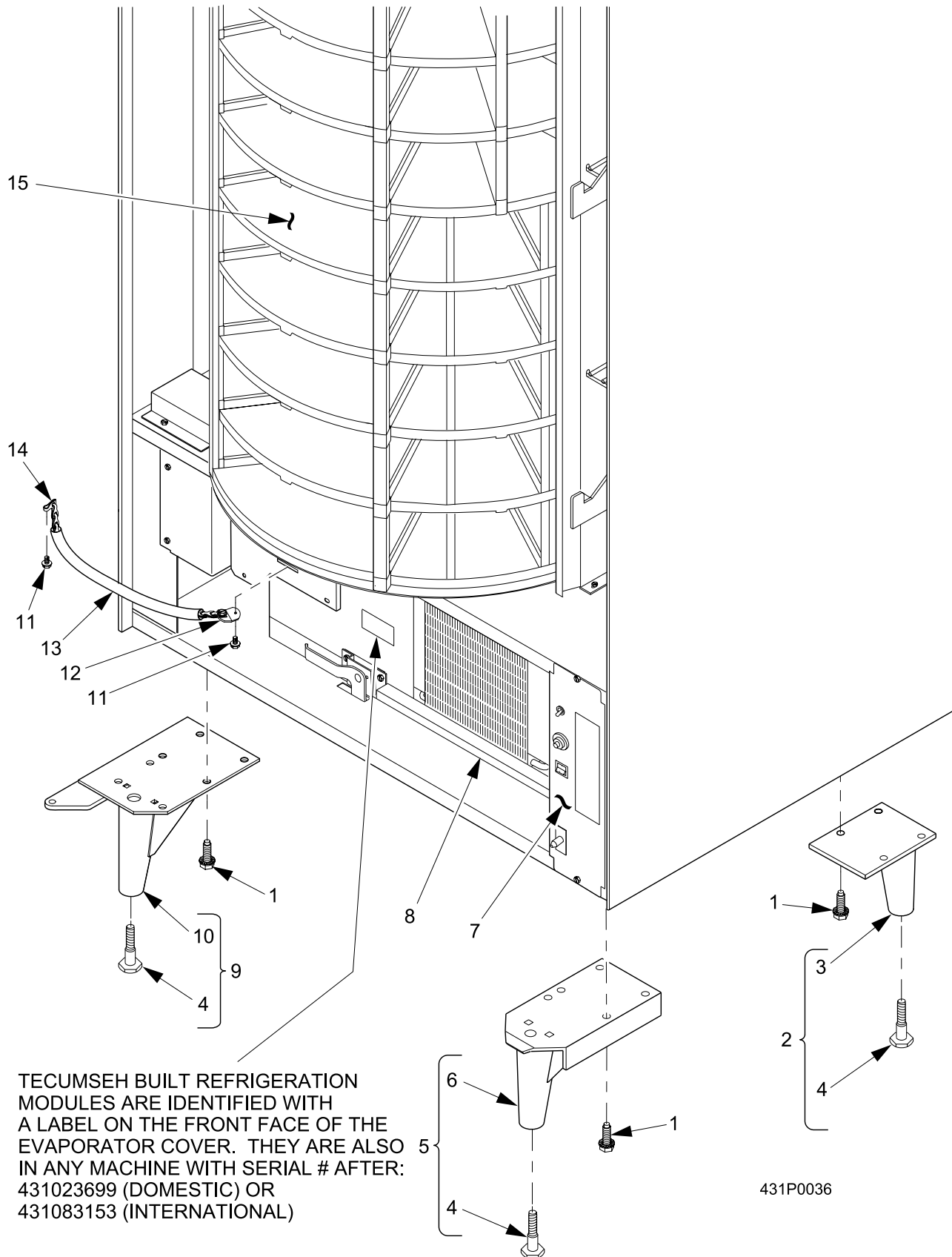
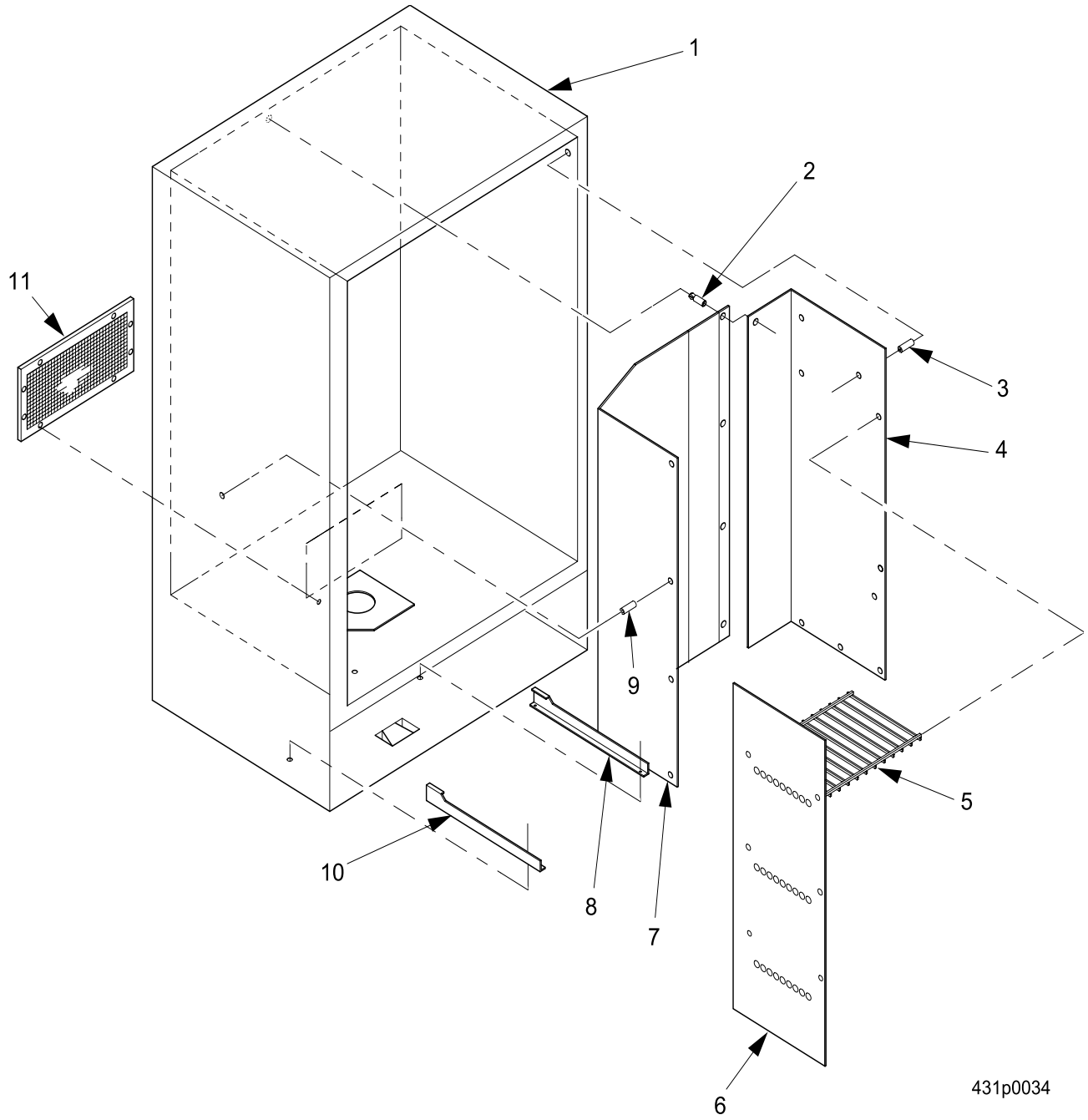

FIGURE 23: CABINET ASSEMBLY (PART 1 OF 4)

TABLE 23: CABINET ASSEMBLY (PART 1 OF 4)

INDEX	PART NUMBER	DESCRIPTION	QTY
1	9900218	SCREW #5/6 X 1 - WITH LOCKING RING	16
2	1471237	LEG & LEVELER ASSEMBLY - CABINET (INCLUDES INDEX NUMBERS 3 & 4)	2
3	4311068	LEG ASSEMBLY - CABINET - WELD	1
4	1471098	LEVELER - CABINET	1
5	4301039	LEG & LEVELER ASSEMBLY - RIGHT FRONT (INCLUDES INDEX NUMBERS 4 & 6)	1
6	4301045	LEG ASSEMBLY - RIGHT FRONT	1
7	4311171	POWER PANEL ASSEMBLY - 115V (SEE TABLE 40 FOR DETAILS)	1
	4311173	POWER PANEL ASSEMBLY - UK - 230V (SEE TABLE 41 FOR DETAILS)	
	4311172	POWER PANEL ASSEMBLY - 230V (SEE TABLE 42 FOR DETAILS)	
8	--	REFRIGERATION UNIT	1
9	4301038	LEG HINGE & LEVELER ASSY. (INCLUDES INDEX NUMBERS 4 & 10)	1
10	4551156	PLATE - MOUNTING - LEG & HINGE	1
11	1471199	SCREW - #8-18 X .62 HEX/WH.	--
12	4301285	BRACKET - DOOR CHAIN	1
13	4302231	COVER - CHAIN	1
14	4302232	CHAIN - SASH - 16.3 LONG	1
15	4317001	TURRET - STANDARD - WHITE	1
	4317008	TURRET - STANDARD - BLACK	



431p0034

FIGURE 24: CABINET ASSEMBLY (PART 2 OF 4)

TABLE 24: CABINET ASSEMBLY (PART 2 OF 4)

INDEX	PART NUMBER	DESCRIPTION	QTY
1	4311200	WELD ASSEMBLY - CABINET	1
2	4311058	GROMMET - DUCT - RETURN AIR - LEFT	4
3	4241160	SPACER - LINER	7
4	4311022	DUCT - RETURN AIR - RIGHT - WHITE	1
	4311156	DUCT - RETURN AIR - RIGHT - BLACK	
5	4301254	SHELF - STORAGE	3
	4311009	WALL - STORAGE - WHITE	
6	4311175	WALL - STORAGE - BLACK	1
	4311178	DUCT - RETURN AIR - LEFT - WHITE	
7	4311179	DUCT - RETURN AIR - LEFT - BLACK	1
8	4314111	RAIL - RIGHT HAND - REFRIGERATION UNIT	1
9	4301230	SPACER - .500 LONG X .50 DIA	8
10	4314110	RAIL - LEFT HAND - REFRIGERATION UNIT	1
11	4311042	SCREEN ASSEMBLY - REAR	1
--	4301235	COVER - TURRET GEAR - WHITE	1
	4301151	COVER - TURRET GEAR - BLACK	
	9901897	COVER - TURRET GEAR - UNPAINTED	

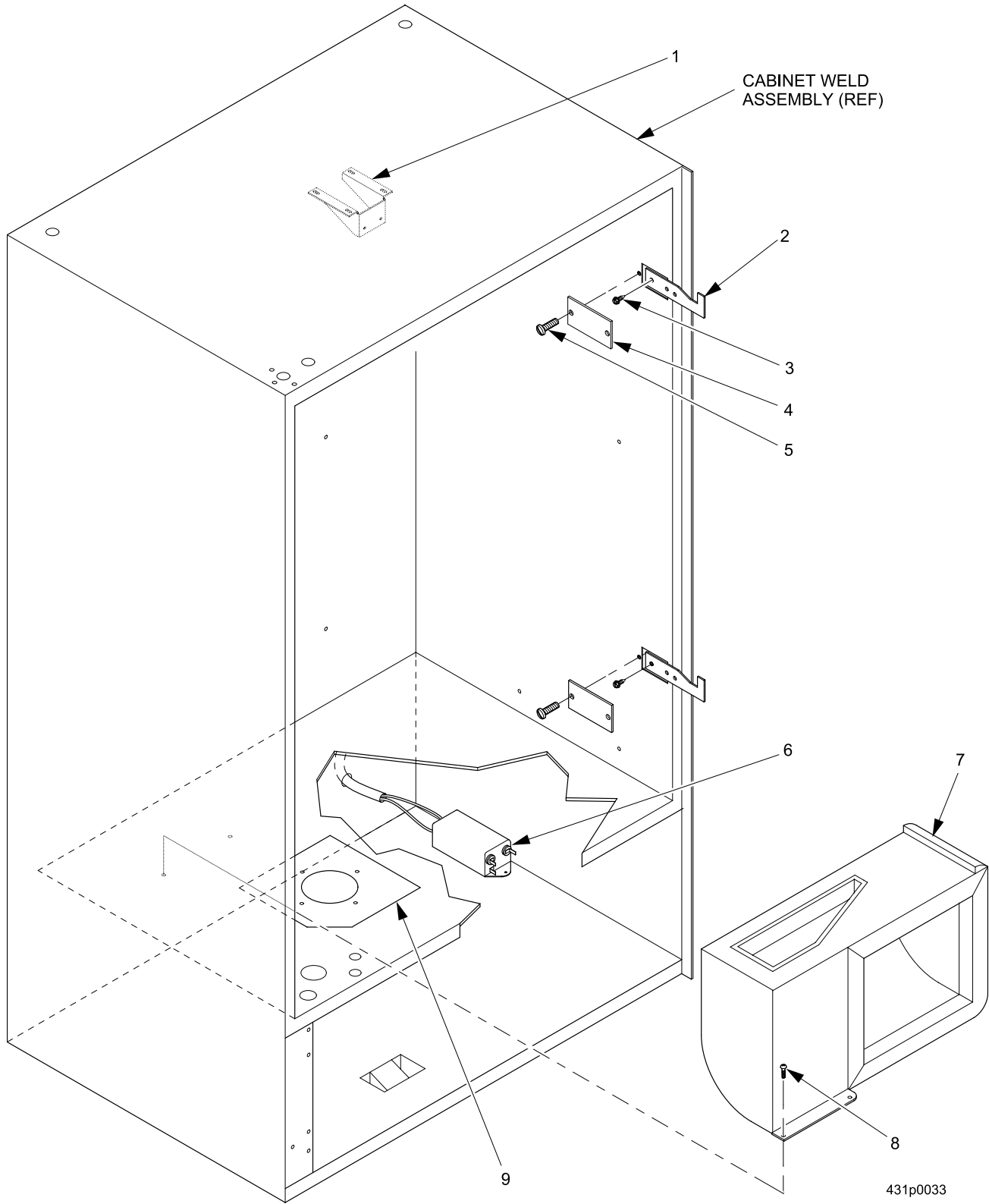

FIGURE 25: CABINET ASSEMBLY (PART 3 OF 4)

TABLE 25: CABINET ASSEMBLY (PART 3 OF 4)

INDEX	PART NUMBER	DESCRIPTION	QTY
1	4301222	BRACKET - TURRET LOCATING	1
2	4301049	LOCK ARM - CABINET	2
3	1141043	#10-32 X 1/2 - NF2- HEX - WASH HD - W/NIBS	4
4	4301216	COVER - CABINET LOCK BAR - WHITE	2
	4301143	COVER - CABINET LOCK BAR - BLACK	
	9901840	COVER - CABINET LOCK BAR - UNPAINTED	
5	2222714	SCREW - SHEET METAL-#8 X 7/8 PHS	4
6	9989110	FILTER - POWER LINE - EMI (230V APPLICATIONS)	1
7	4314079	DUCT & SEAL ASSEMBLY - RETURN	1
8	9900160	SCREW - #8-18 X 1/2"PHIL.PAN HD.	--
9	4317004	PLATE - ROLLER - CABINET	1

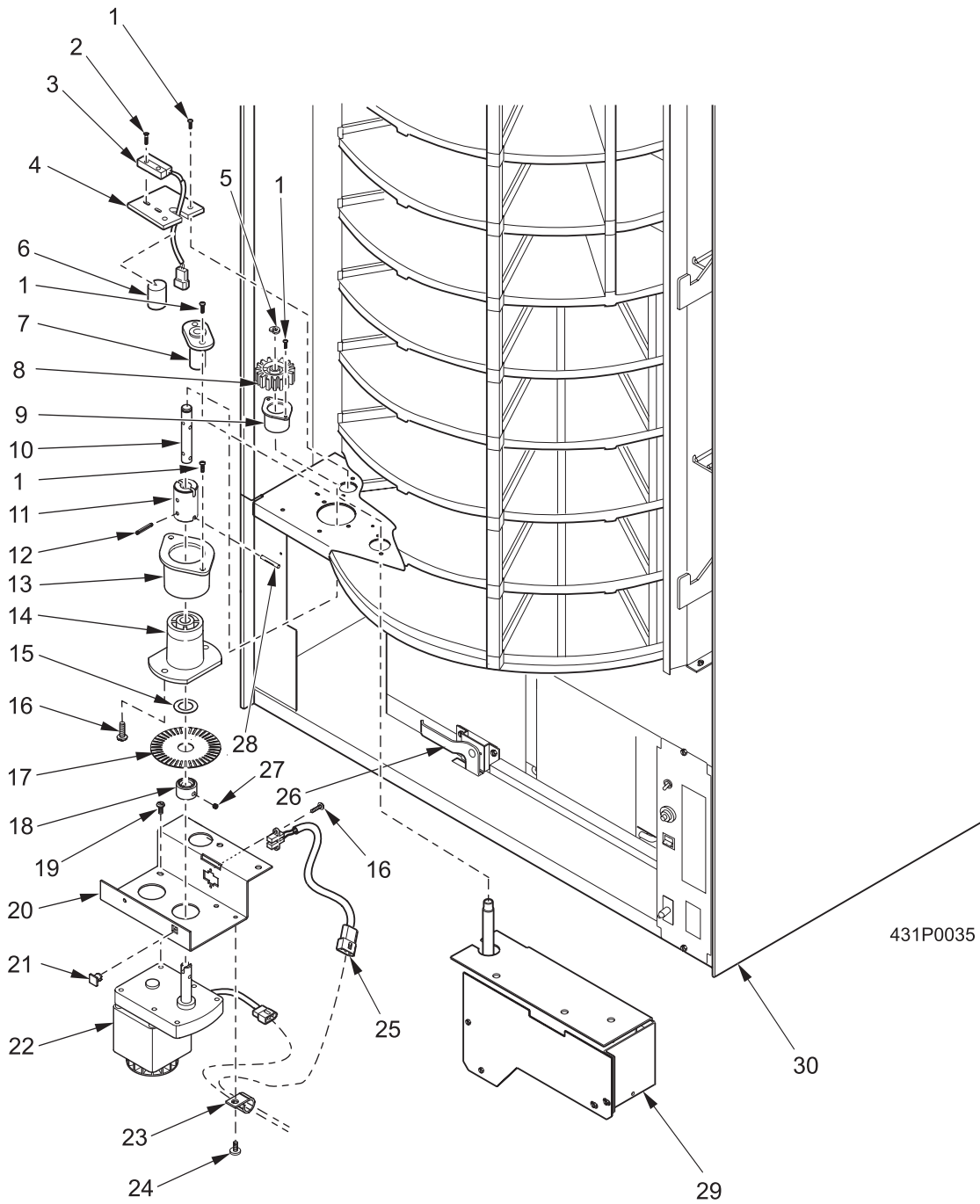

FIGURE 26: CABINET ASSEMBLY (PART 4 OF 4)

TABLE 26: CABINET ASSEMBLY (PART 4 OF 4)

INDEX	PART NUMBER	DESCRIPTION	QTY
1	4312213	SCREW #8-32 X.50 THS S/TAPPING	6
2	1212140	SCREW - #4-40 X 1/4 RHS	2
3	4329022	SENSOR - PROXIMITY	1
4	4301351	PLATE - SENSOR	1
5	9900437	RETAINING RING REINF E TYP.375	1
6	4301368	INSULATION - 1.00 DIA X 1.62	1
7	4311237	BUSHING - STOP PIN	1
8	4301396	DRIVE GEAR	1
9	4301205	HOUSING - BUSHING	1
--	4301398	BUSHING & DRIVE SHAFT ASSY (INCLUDES ITEMS 10-12, 14)	1
10	4301395	DRIVE SHAFT	1
11	4301394	DRIVE - COUPLING	1
12	3127034	ROLL PIN 1/8 X 3/16	1
13	4301205	HOUSING - BUSHING	1
14	4301206	BUSHING - DRIVE SHAFT	1
--	4311125 4311127	DRIVE MOTOR ASSEMBLY-115V DRIVE MOTOR ASSEMBLY-230V (INCLUDES ITEMS 15-25, 27)	1
--	4301525	WHEEL ASSY-OPTICAL SWITCH ASSY (INCLUDES 15-18)	1
15	4301521	WASHER - OPTICAL WHEEL	1
16	4271062	SCREW - #4-24 X .375 PH Z-P S.T.	2
17	4301524	WHEEL - OPTICAL SWITCH	1
18	4301378	BUSHING - SWITCH WHEEL	1
19	9900118	SCREW - #8-32 X 3/8 PHS	2
20	4311216	BRACKET - MOTOR - TURRET	1
21	4241162	NUT - SPACER - #8-.062	2
22	4311124	MOTOR - REVERSIBLE	1
	4311126	MOTOR - REVERSIBLE - 230V	
23	1452139	RETAINER - HARNESS	1
24	9900160	SCREW - #8-18 X 1/2"PHIL.PAN HD.	1
25	4319012	MOTION DETECTOR ASSEMBLY	1
26	4111149	LATCH ASSEMBLY - DOOR	1
27	4301380	SET SCREW - #8-32 X 3/16 - COVE PT	1
28	4301375	GROOVE - PIN - .125 DIA.X.875 LG.	1
29	4311108	STOP PIN ASSEMBLY - DOMESTIC 115V	1
	4311109	STOP PIN ASSEMBLY - 230V	
30	4311219	CABINET WELD ASSEMBLY - N.V. BLACK	1
	4311220	CABINET WELD ASSEMBLY - MILLENNIA GRAY	
	4311227	CABINET WELD ASSEMBLY - MIR BLACK	
	4311229	CABINET WELD ASSEMBLY - SELECTA WHITE	

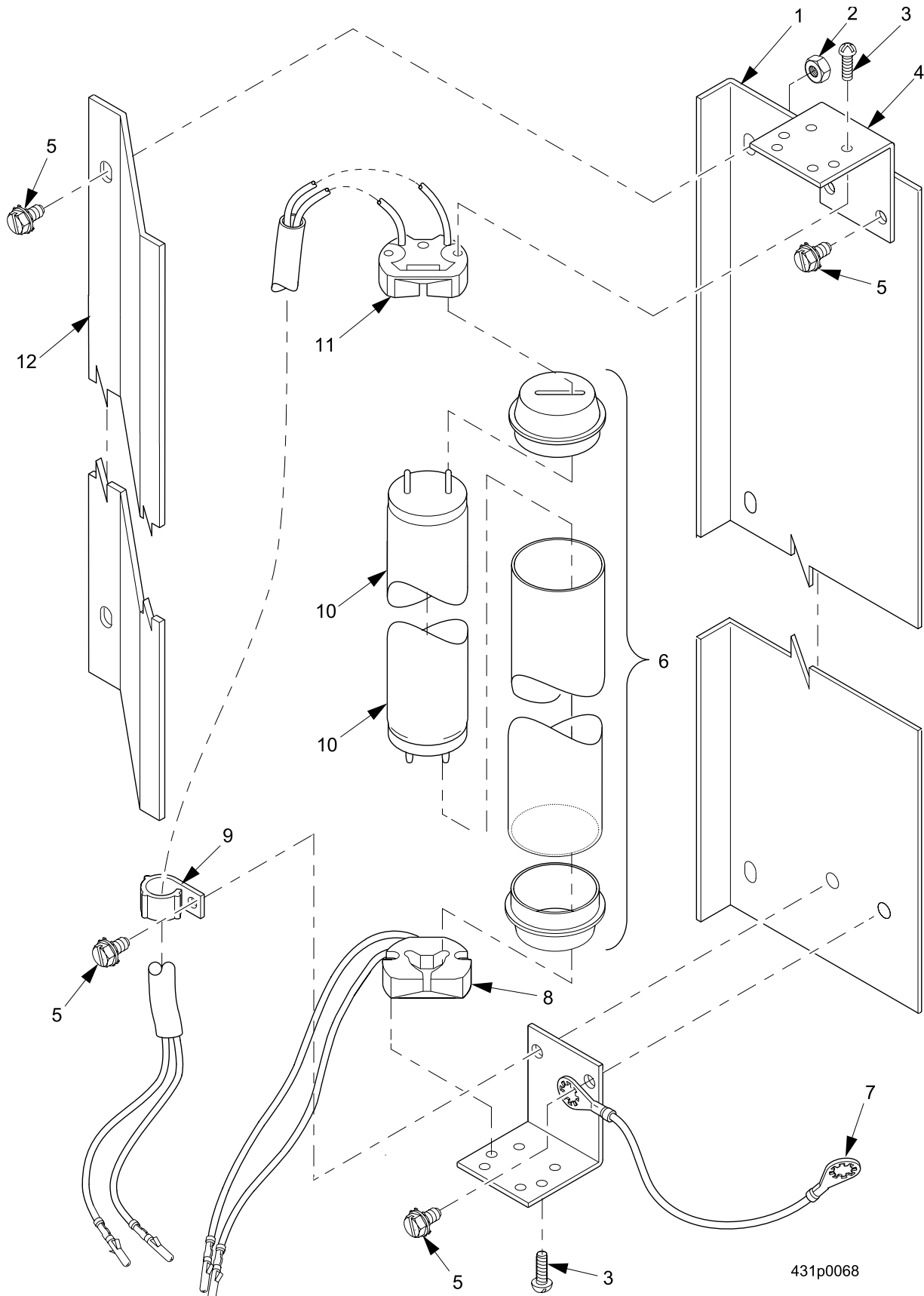

FIGURE 27: LIGHT ASSEMBLY - HINGE SIDE

TABLE 27: LIGHT ASSEMBLY - HINGE SIDE

INDEX	PART NUMBER	DESCRIPTION	QTY
--	4312072	FLUORESCENT LIGHT BRACKET ASSEMBLY - WHITE	--
	4312078	FLUORESCENT LIGHT BRACKET ASSEMBLY - BLACK	
1	4312130	BRACKET - LIGHT - WHITE	1
	4312131	BRACKET - LIGHT - BLACK	
2	9900071	NUT #4-40	4
3	9900219	SCREW - #4-36 X .437 RH PHILLIPS	4
4	4302086	ANGLE - LIGHT - WHITE	2
	4302396	ANGLE - LIGHT - BLACK	
5	3157060	SCREW - #8-32 X .31 HEX W/ HD. S	4
6	4302069	SAFETY SLEEVE ASSEMBLY	1
7	1475119	JUMPER - GROUND WIRE	1
8	4302277	FLUORESCENT SOCKET - LOWER	1
9	2342315	CLIP - WIRE HARNESS	1
10	4031149	LAMP - FLUORESCENT - 40 WATT	1
11	4302276	FLUORESCENT SOCKET - UPPER	1
12	4312132	SHIELD - LIGHT - WHITE	2
	4312133	SHIELD - LIGHT - BLACK	
--	4311083	COVER - SOCKET (NOT SHOWN)	2
	4311012	COVER - SOCKET - BLACK (NOT SHOWN)	

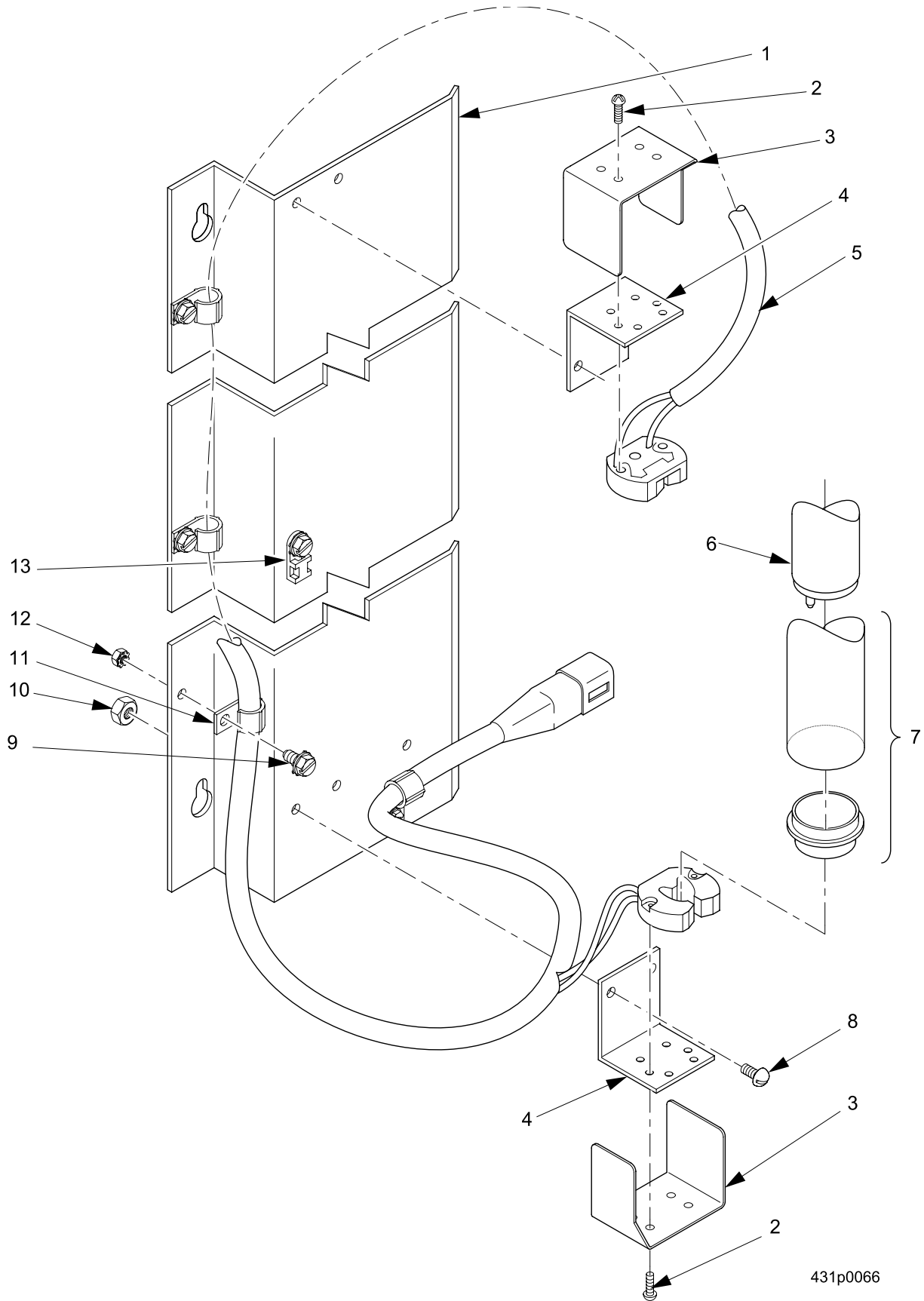

FIGURE 28: LIGHT ASSEMBLY - LOCK SIDE

TABLE 28: LIGHT ASSEMBLY - LOCK SIDE

INDEX	PART NUMBER	DESCRIPTION	QTY
--	4302187	MECH. COVER & LIGHT BRACKET ASSEMBLY - WHITE - 115V	--
	4302398	MECH. COVER & LIGHT BRACKET ASSEMBLY - BLACK - 115V	
	4302569	MECH. COVER & LIGHT BRACKET ASSEMBLY - BLACK - 230V	
1	4302646	COVER - MECHANISM - WHITE	1
	4302647	COVER - MECHANISM - BLACK	
2	9900219	SCREW - #4-36 X .437 RH PHILLIPS	8
3	4311083	COVER - SOCKET	2
	4311012	COVER - SOCKET - BLACK	
4	4302086	ANGLE - LIGHT - WHITE	2
	4302396	ANGLE - LIGHT - BLACK	
5	4319026	HARNESS - FLUORESCENT LIGHT	1
6	4031149	LAMP - FLUORESCENT - 40W	1
7	4302069	SAFETY SLEEVE ASSEMBLY - WITH END CAPS	1
8	9900019	SCREW - #8-32 X 3/8 RHS	3
9	3157060	SCREW - #8-32 X .31 HEX W/ HD. S	9
10	9900071	NUT #4-40	8
11	1452139	RETAINER - HARNESS	6
12	9900081	NUT #8-32 KEPS ZINC PLATE	3
13	4302245	ANCHOR - CABLE TIE IITAI - S8M	1
--	4319026	HARNESS - FLUORESCENT LIGHT	1

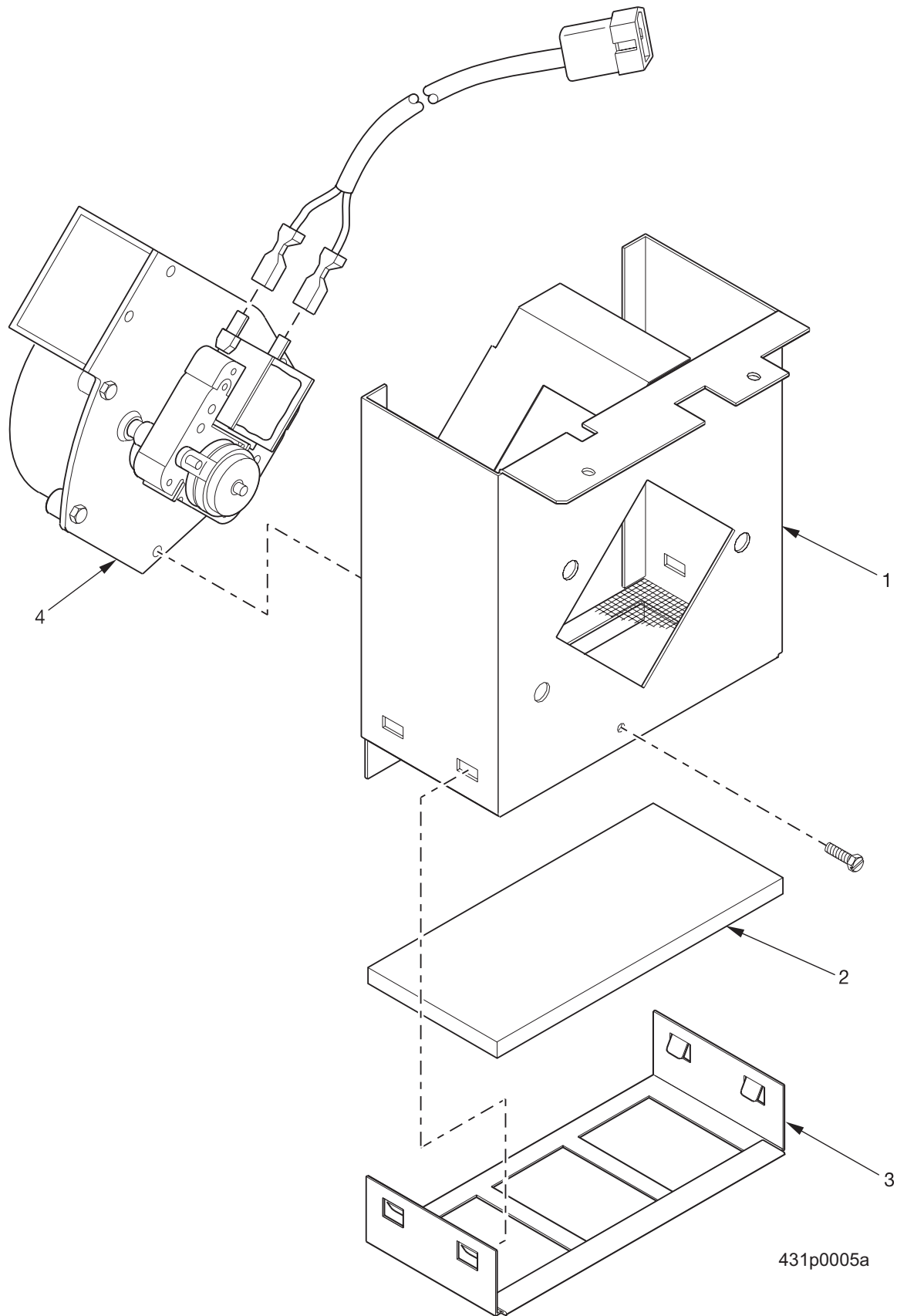
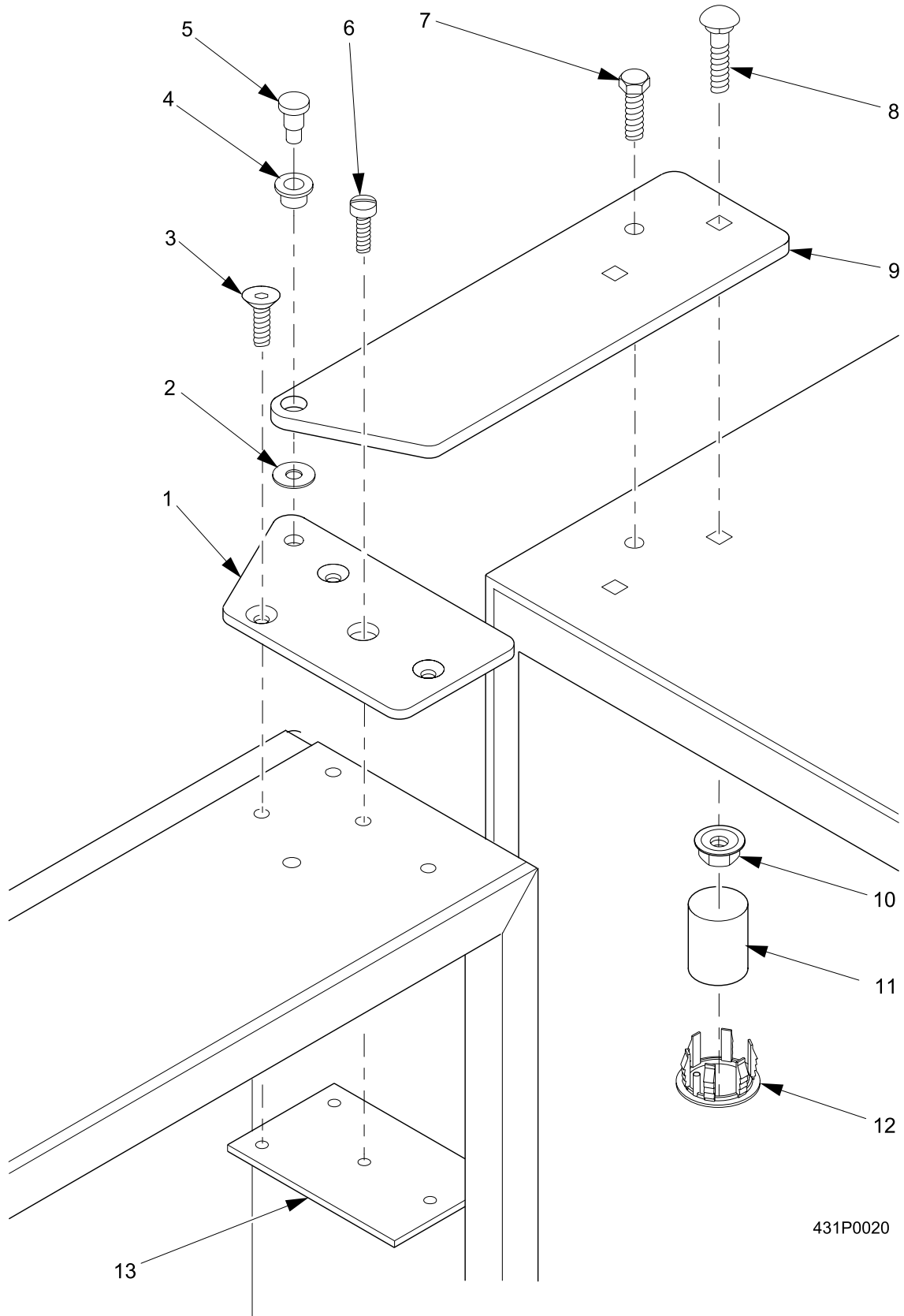

FIGURE 29: DUCT - BLOWER ASSEMBLY

TABLE 29: DUCT - BLOWER ASSEMBLY

INDEX	PART NUMBER	DESCRIPTION	QTY
--	4312010	DUCT - BLOWER ASSEMBLY - 115V	--
	4312050	DUCT - BLOWER ASSEMBLY - 220V	
1	4312011	WELD ASSEMBLY - DUCT BLOWER	1
2	4312016	FILTER - DOOR DUCT	1
3	4312015	RETAINER - FILTER	1
4	4312210	BLOWER ASSEMBLY - 120V	1
	4312211	BLOWER ASSEMBLY - 230V	



431P0020

FIGURE 30: UPPER HINGE ASSEMBLY

TABLE 30: UPPER HINGE ASSEMBLY

INDEX	PART NUMBER	DESCRIPTION	QTY
--	4312006	HINGE ASSEMBLY - DOOR - UPPER	--
	4312108	HINGE ASSEMBLY - DOOR - UPPER - GRAY	
	4312135	HINGE ASSEMBLY - DOOR - UPPER - SELECTA WHITE	
	4312212	HINGE ASSEMBLY - DOOR - UPPER - BLACK	
1	4302041	PLATE - DOOR HINGE - UPPER	1
2	1172261	WASHER - SPACER .69X.265X22GA CR	1
3	4311235	SCREW #1/4 - 20 X .75 - FLATHEAD W/ SEMS	5
4	1172262	BUSHING - DOOR HINGE - UPPER	1
5	3152398	PIN - DOOR HINGE - UPPER	1
6	5264629	09126026 SCREW - LOCK - PLATED	1
7	1171052	5/16 - 18 X 3/4 HEX HD - CAP - ZP	1
8	1171021	5/16 - 18 X 3/4 CARRIAGE BOLT - ZP	2
9	4312007	PLATE - HINGE - UPPER	1
10	1171022	5/16 - 18 KEPS NUT - CONICAL/SERRATED WASHER	2
11	4301256	INSULATION - HOLE PLUG	2
12	4311096	PLUG - FOAMING HOLE	4
13	4302037	NUT PLATE - UPPER HOUSE	1

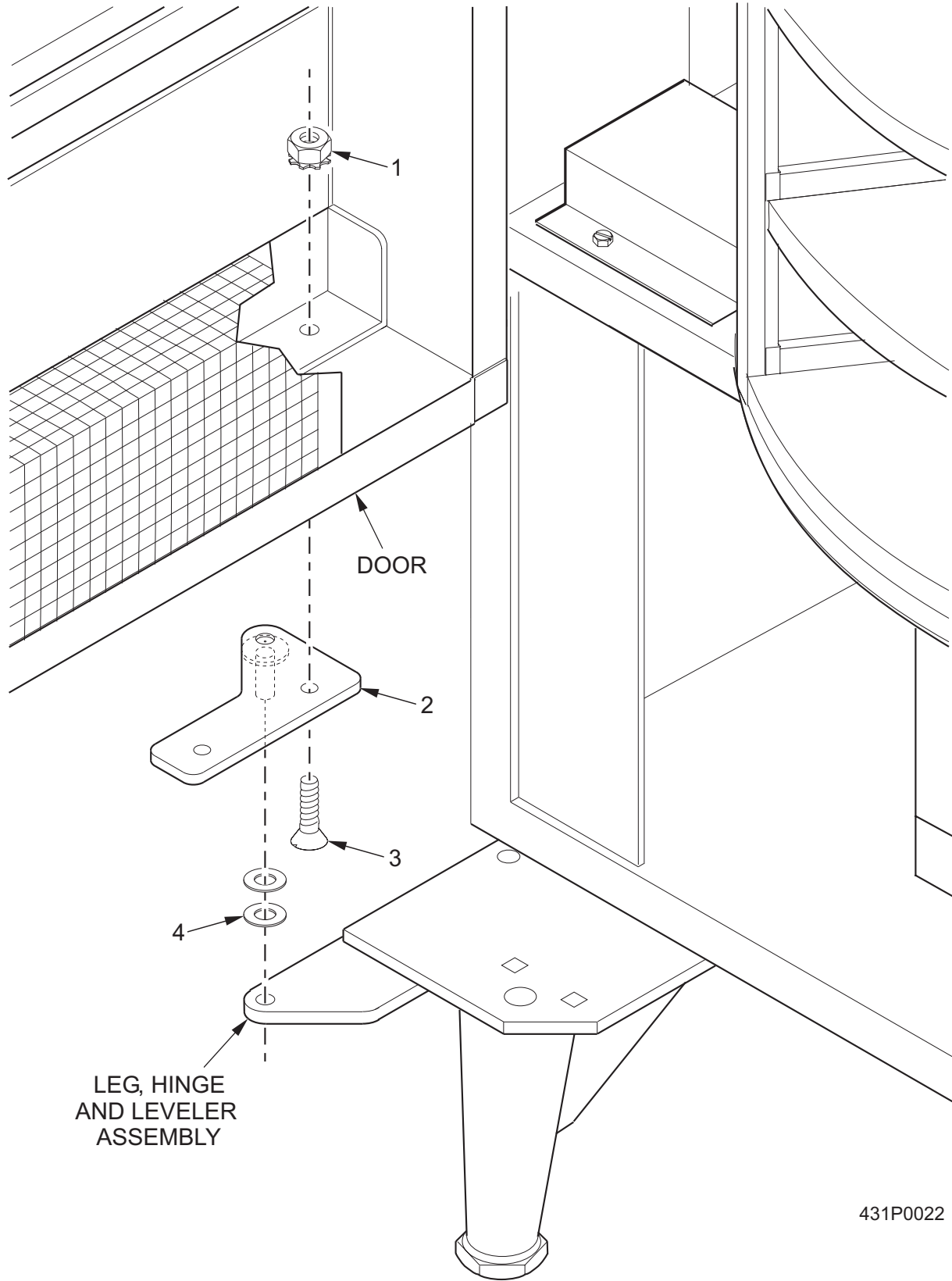
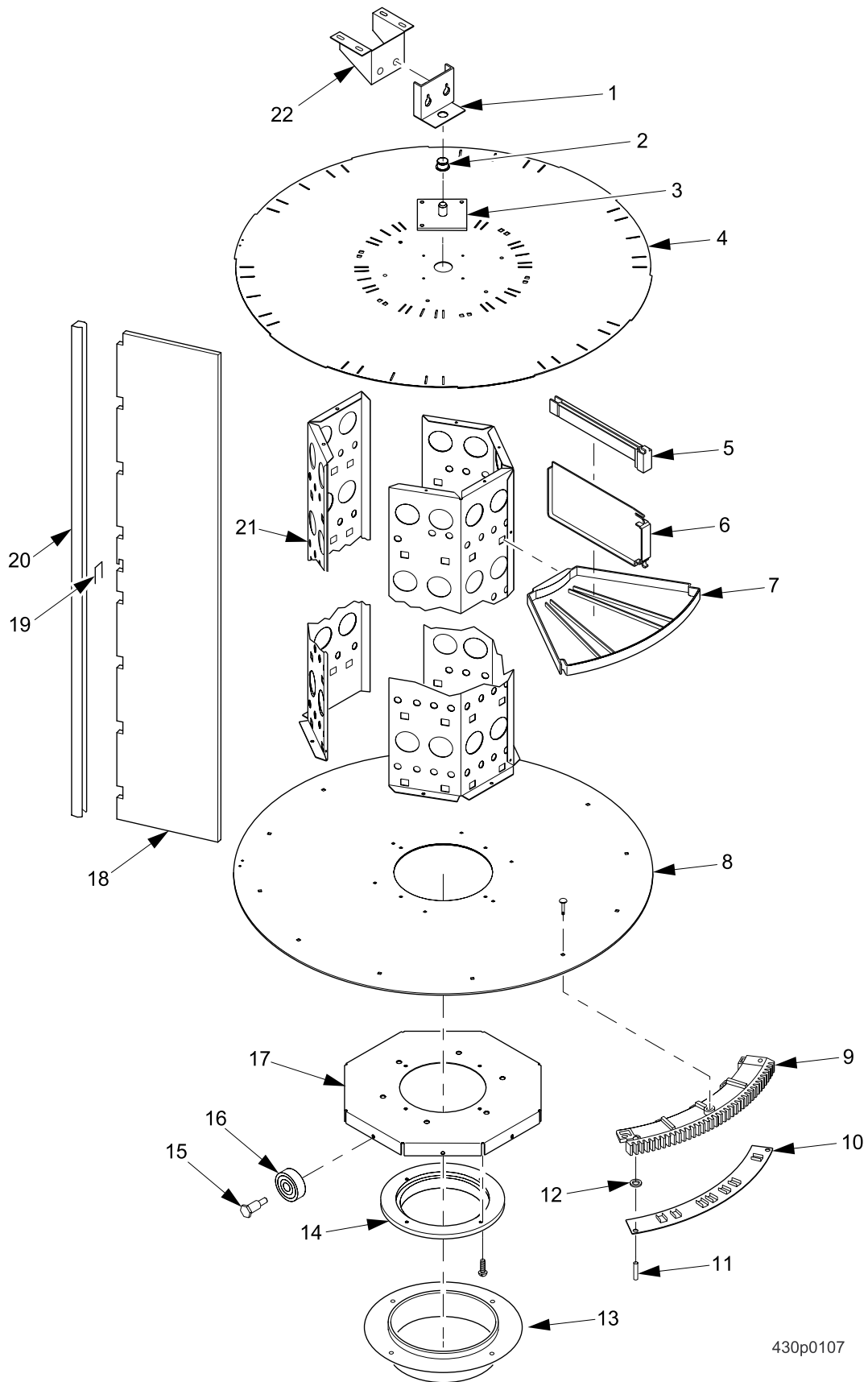

FIGURE 31: LOWER HINGE ASSEMBLY

TABLE 31: LOWER HINGE ASSEMBLY

INDEX	PART NUMBER	DESCRIPTION	QTY
--	4312091	HINGE ASSEMBLY - DOOR - LOWER - PAINTED	--
1	1211105	1/4 - 20 KEPS NUT - EXT. LW - Z/P	2
2	4312093	PLATE - LOWER HINGE - PAINTED	1
3	4311235	SCREW #1/4 - 20 X .75 - FLATHEAD - W/SEMS	2
4	4242145	BEARING - THRUST - LOWER HINGE	2



430p0107

FIGURE 32: TURRET ASSEMBLY

TABLE 32: TURRET ASSEMBLY

INDEX	PART NUMBER	DESCRIPTION	QTY
--	4317001	TURRET - STANDARD - WHITE	1
	4317008	TURRET - STANDARD - BLACK	
1	4311224	BRACKET - BEARING SUPPORT - TURRET	1
2	4311225	BEARING - FLANGED - OILITE FB810-4	1
3	4307032	PIN & PLATE ASSEMBLY	1
4	4307038	TURRET - TOP - WHITE	1
	4307045	TURRET - TOP - BLACK	
5	4307036	RETAINER - SHELF	84
6	4307035	DIVIDER - SHELF	28
7	4307034	SHELF - PRODUCT	54
8	4317006	BASE - TURRET - WHITE	1
	4317002	BASE - TURRET - BLACK	
9	4307017	GEAR SEGMENT - TURRET	6
10	4307018	PLATE - STOP	6
11	4301353	MAGNET - MAGNETIZED	1
12	5277437	SPACER - NYLON	1
13	4311054	BEARING - TURRET	1
14	4311055	LOCATOR - TURRET	1
15	4241264	STUD - ROLLER - TRAY	12
16	4307015	ROLLER - TURRET	8
17	4317003	PLATE - MOUNTING - ROLLER	1
18	4307028	WALL - SHELF - WHITE (WHITE DRUM ONLY)	3
	4307009	WALL - SHELF (WHITE DRUM ONLY)	
	4307046	WALL - SHELF (SMOKED) (BLACK DRUM ONLY)	6
19	4307027	RETAINER - RAIL	6
20	4307026	RAIL - TURRET	6
21	4317012	PANEL - CENTER - TURRET - WHITE	3
	4317011	PANEL - CENTER - TURRET - BLACK	
22	4301222	BRACKET - TURRET LOCATING	1

THE FOLLOWING KIT IS ALSO AVAILABLE

4301374	KIT - SENSOR REPLACEMENT (INCLUDES ITEMS 1-4 PLUS MAGNET LOCATED IN ONE OF THE TURRET GEAR SEGMENTS) (SEE TABLE 32 FOR DETAILS)
---------	---

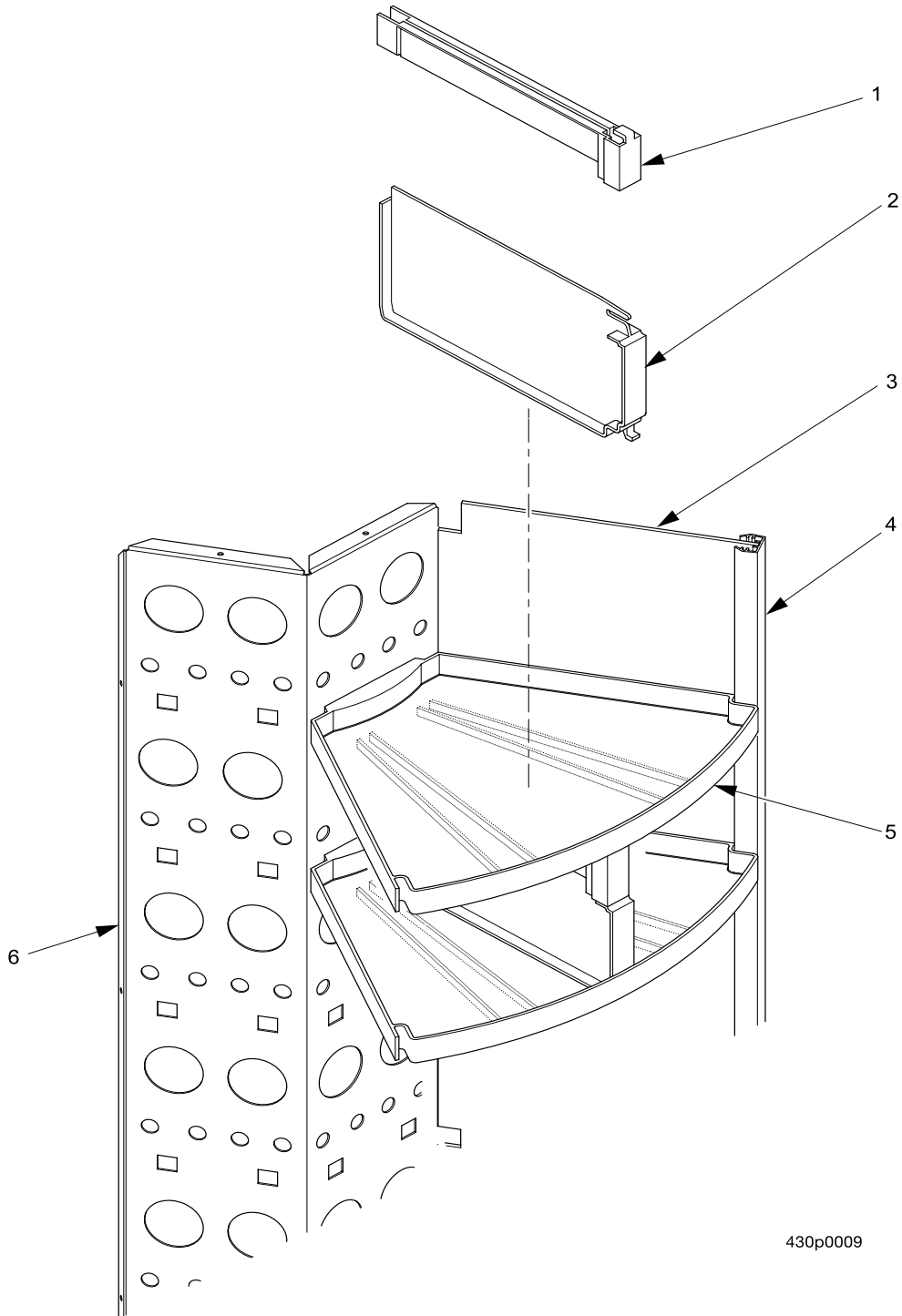
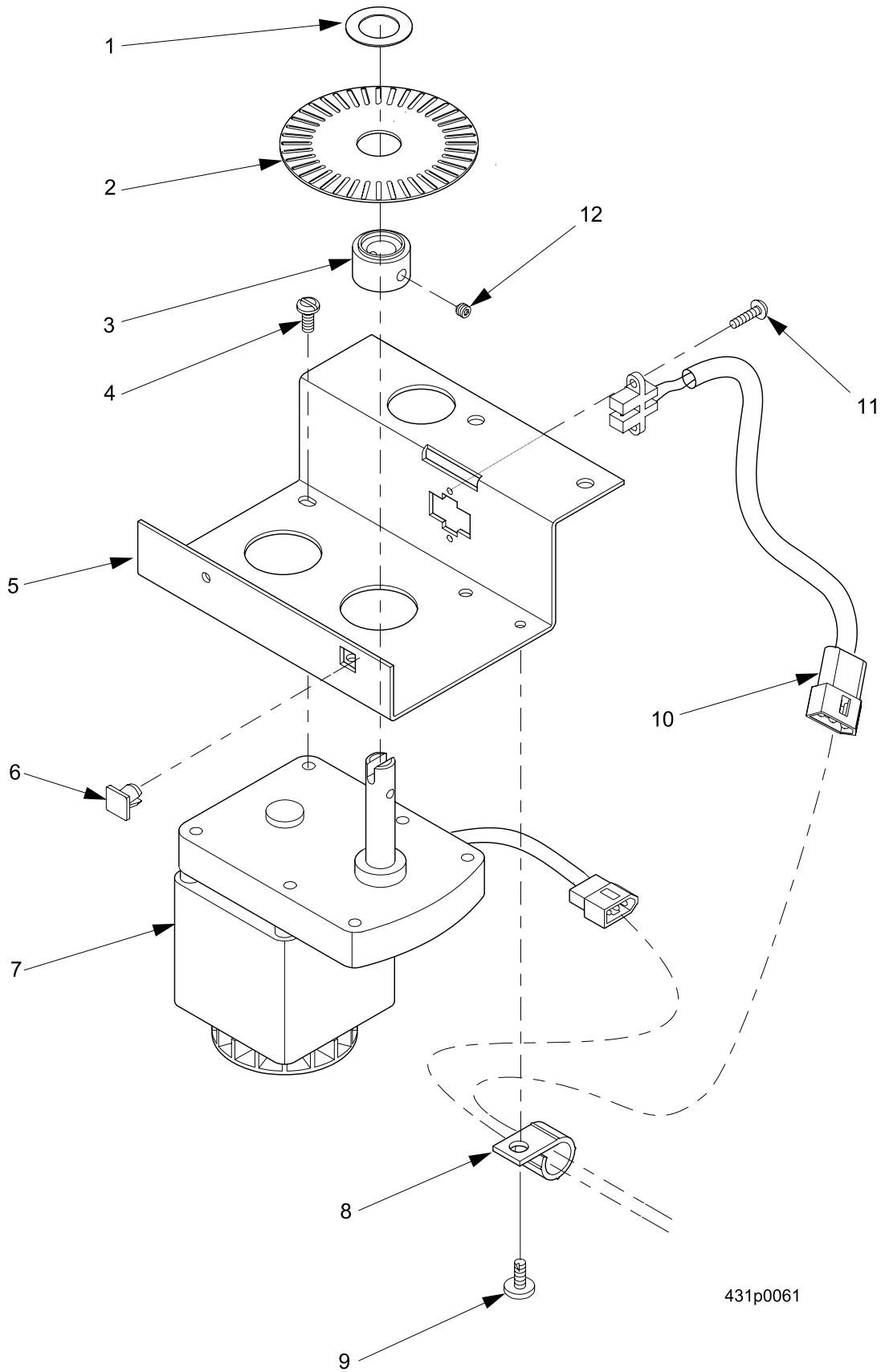

FIGURE 33: DRUM ASSEMBLY

TABLE 33: DRUM ASSEMBLY

INDEX	PART NUMBER	DESCRIPTION	QTY
1	4307036	RETAINER - SHELF	6
2	4307035	DIVIDER - SHELF	84
3	4307028	WALL - SHELF - WHITE (WHITE DRUM ONLY)	3
	4307009	WALL - SHELF - CLEAR (WHITE DRUM ONLY)	
	4307046	WALL - SHELF - (SMOKED) (BLACK DRUM ONLY)	6
4	4307026	RAIL - TURRET	6
5	4307034	SHELF - PRODUCT	54
6	4317011	PANEL - CENTER - TURRET-BLACK	3
	4317012	PANEL - CENTER - TURRET - WHITE	
--	4307027	RETAINER - RAIL (NOT SHOWN)	6



431p0061

FIGURE 34: DRIVE MOTOR ASSEMBLY

TABLE 34: DRIVE MOTOR ASSEMBLY

INDEX	PART NUMBER	DESCRIPTION	QTY
--	4311125	DRIVE MOTOR ASSEMBLY - 115V	REF
	4311127	DRIVE MOTOR ASSEMBLY - 230V	
--	4301525	WHEEL ASSEMBLY - OPTICAL SWITCH (INCLUDES ITEMS 1, 2 & 12)	REF
1	4301521	WASHER - OPTICAL WHEEL	1
2	4301524	WHEEL ASSEMBLY - OPTICAL SWITCH	1
3	4301378	BUSHING - SWITCH WHEEL	1
4	9900118	SCREW #8-32 X 3/8 PHS	4
5	4311216	BRACKET - MOTOR - TURRET	1
6	4241162	NUT - SPACER - #8-.062	1
7	4311124	MOTOR - REVERSIBLE - 115V	1
	4311126	MOTOR - REVERSIBLE - 230V	
8	1452139	RETAINER - HARNESS	1
9	9900160	SCREW - #8-18 X 1/2" PHIL.PAN HD.	1
10	4319012	MOTION DETECTOR ASSEMBLY	1
11	4271062	SCREW - #4-24 X .375 PH Z-P S.T.	2
12	4301380	SET SCREW #8-32 X 3/16 - CWE PT.	1

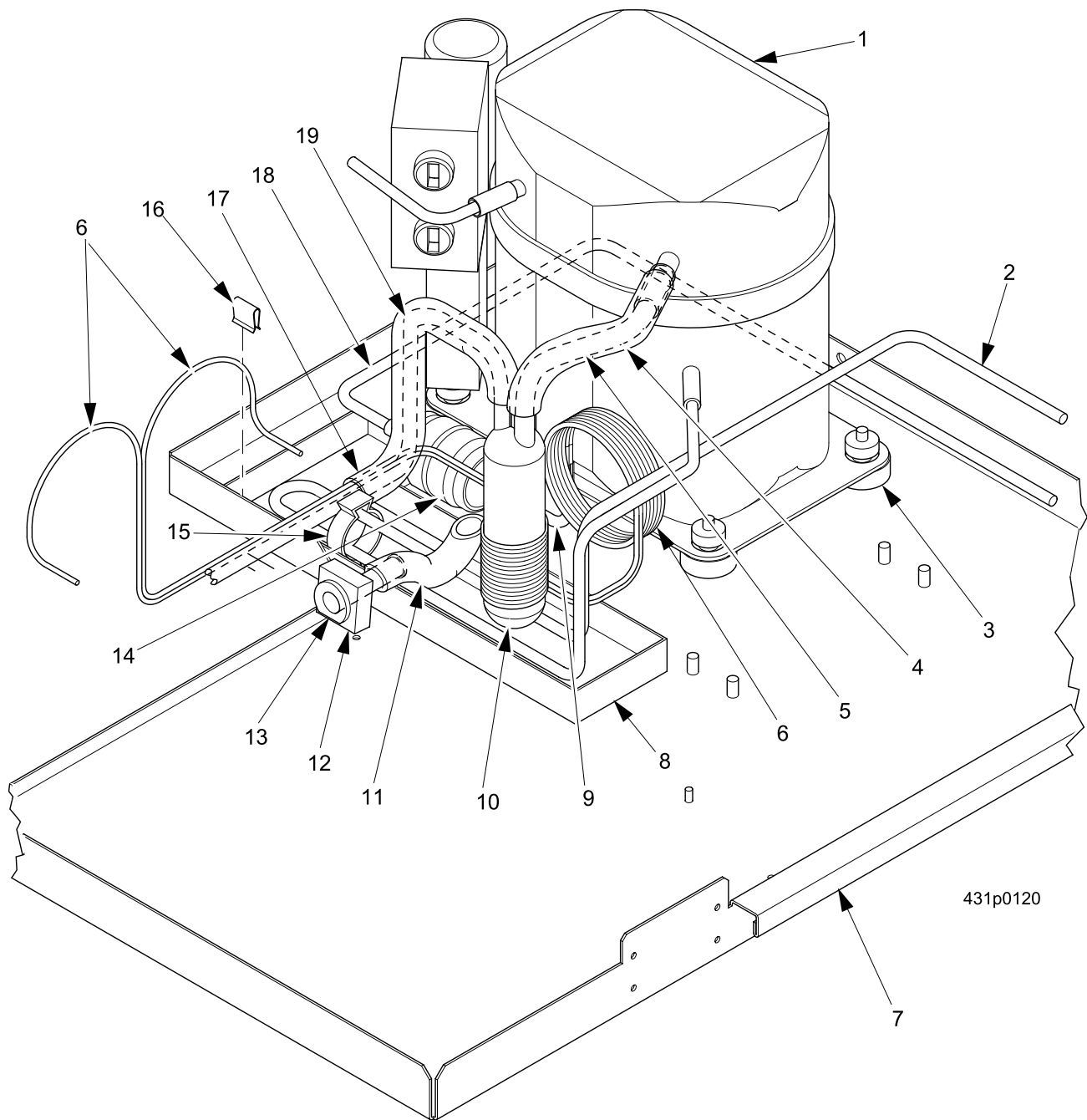
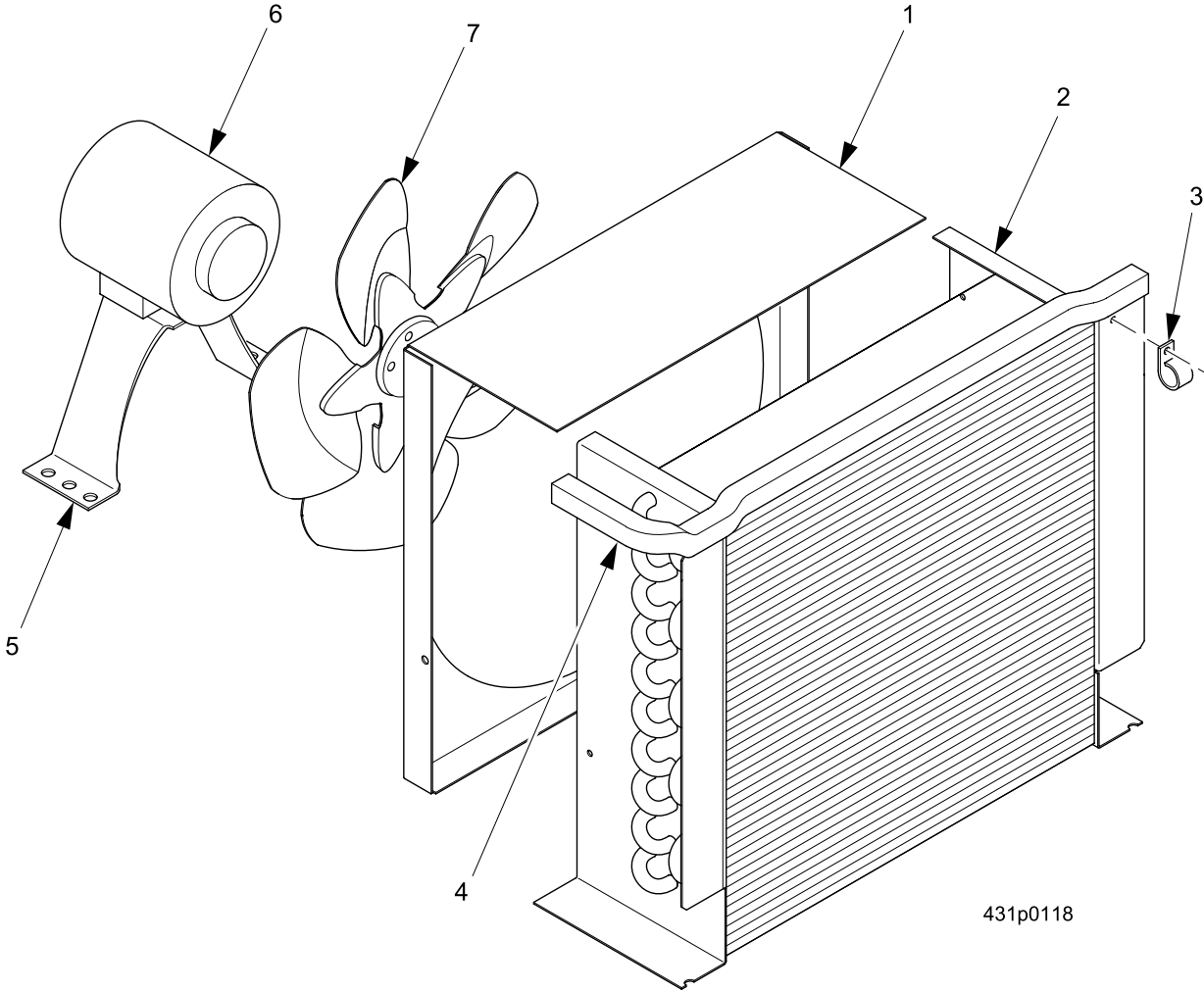

FIGURE 35: COMPRESSOR ASSEMBLY

TABLE 35: COMPRESSOR ASSEMBLY

INDEX	PART NUMBER	DESCRIPTION	QTY
--	4314000	REFRIGERATION UNIT - 115V-R134A (FOR MERCHANTISERS WITH SERIAL # PRIOR TO 431-023699)	--
	4314134	REFRIGERATION UNIT - 115V 60HZ (FOR MERCHANTISERS WITH SERIAL # AFTER TO 431-023698)	
--	4314048	REFRIG.UNIT-220V-R134A (FOR MERCHANTISERS WITH SERIAL # PRIOR TO 431-083153)	--
	4314135	REFRIGERATION UNIT-230V 50HZ (FOR MERCHANTISERS WITH SERIAL # PRIOR TO 431-083152)	
1	4314037	COMPRESSOR - 115V-R134A	1
	4314055	COMPRESSOR - 220V-R134A	
2	4314044	TUBE - DISCH.LINE - COMPRESSOR TO CONDENSER	--
3	4254027	GROMMET - 15/16 HEIGHT	4
4	4314133	INSULATION - SUCTION LINE - UPPER	1
5	4314041 L	TUBE - SUCTION LINE - ACCUMULATOR TO COMPRESSOR	1
6	9084349 L	CAP TUBE - COPPER - .059 ID X .112	2
7	4314071 L	BASE - REFRIGERATION MODULE	1
8	4304067 L	PAN - CONDENSATE	1
9	4304220	ADAPTOR - DRIER TO CAP.TUBE	1
10	4244009	ACCUMULATOR P-H 22-056380-01	1
11	4314065	DRAIN - CONDENSATE	1
12	4314114	SEAL - TUBE - DRAIN	1
13	4314027	SPOUT - DRAIN	1
14	4304194	DRIER - C-032S 1/4 SWEAT V	1
15	4304195	HANGER - DRIER	1
16	3124031	RETAINER CLIP - CONDENSER	1
17	4244026	INSULATION - SUCTION LINE - LOWER	1
	4314040	TUBE - EVAPORATOR TO ACCUMULATOR	
18	4314045	TUBE - LIQUID LINE - CONDENSER TO DRIER	1
19	4314040	TUBE - EVAPORATOR TO ACCUMULATOR	1

4314066 (115V)	THIS AFTERMARKET BAG ASSEMBLY IS AVAILABLE FOR THE FOLLOWING COMPRESSOR WEAR ITEMS: START RELAY, THERMAL OVERLOAD, CAPACITOR ALONG WITH ASSOCIATED MOUNTING HARDWARE. CALL OUR PARTS DEPARTMENT AT: 1-800-621-7278	--
4314067 (230V)	THIS AFTERMARKET BAG ASSEMBLY IS AVAILABLE FOR THE FOLLOWING COMPRESSOR WEAR ITEMS: START RELAY, THERMAL OVERLOAD, CAPACITOR ALONG WITH ASSOCIATED MOUNTING HARDWARE. CALL OUR PARTS DEPARTMENT AT: 1-800-621-7278	--



431p0118

FIGURE 36: CONDENSER

TABLE 36: CONDENSER

INDEX	PART NUMBER	DESCRIPTION	QTY
1	4314035	SHROUD - CONDENSER COIL	1
2	4314034	CONDENSER	1
3	4751060	RETAINER - HARNESS	2
4	4744031	SEAL-.50 X.50	17
5	4043066	BRACKET CONDENSER MOTOR S5954TC	1
6	4314089	MOTOR - CONDENSER FAN - 16W - MORILL	1
	4304231	MOTOR - CONDENSER - 16 WATT	
7	4314036	BLADE - CONDENSER FAN (FOR)	1

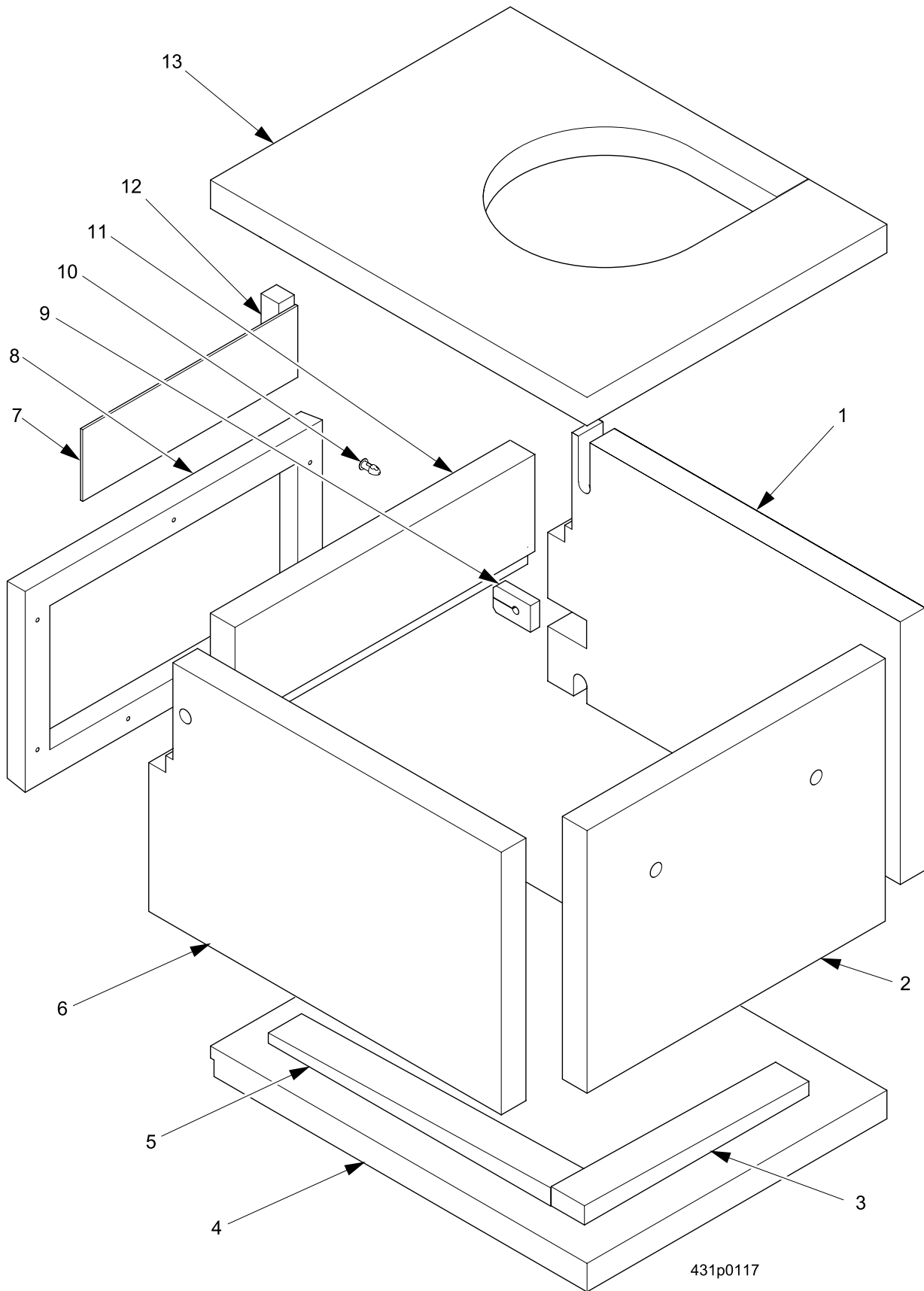

431p0117

FIGURE 37: INSULATION

TABLE 37: INSULATION

INDEX	PART NUMBER	DESCRIPTION	QTY
1	4314101	INSULATION - 1.0" - CENTER	1
2	4314102	INSULATION - 1.0" - FRONT	1
3	4314105	SHIM - FRONT	1
4	4314100	INSULATION - 1.0" - BOTTOM	1
5	4314106	SHIM - LEFT	1
6	4314103	INSULATION - 1.0" - LEFT	1
7	4314125	INSULATION - .12 - REAR - OUTER	1
8	4314098	GASKET - EVAPORATOR - INLET	1
9	4314096	SEAL - TUBE - EVAPORATOR	2
10	4314107	CLIP - PANEL - PUSH IN	7
11	4314104	INSULATION - 1.0" - REAR	1
12	4614027	SEAL - 1.00 X .87	--
13	4314099	INSULATION - 1.0" - TOP	1

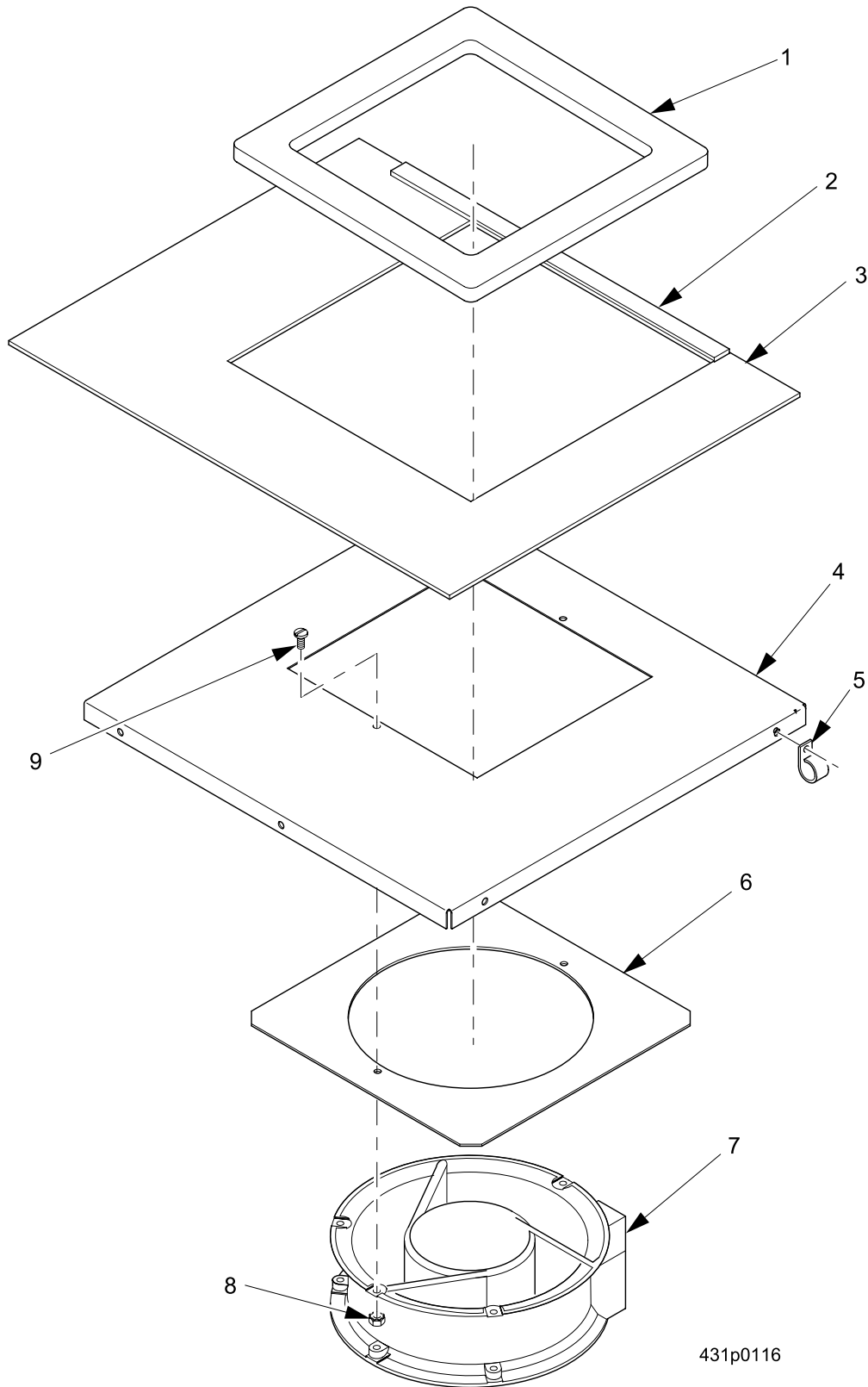
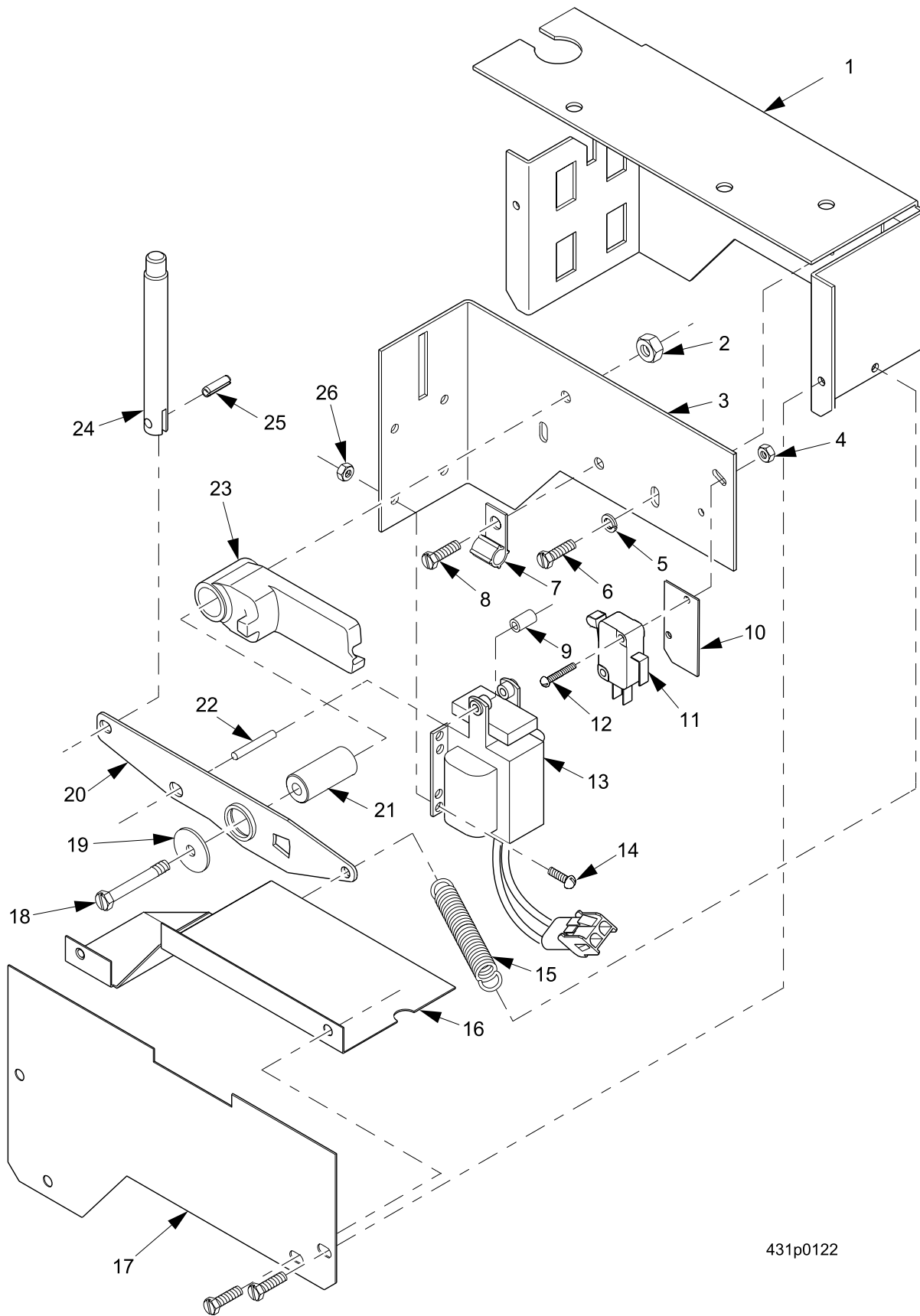

FIGURE 38: EVAPORATOR LID FAN ASSEMBLY

TABLE 38: EVAPORATOR LID FAN ASSEMBLY

INDEX	PART NUMBER	DESCRIPTION	QTY
--	4314119	EVAPORATOR FAN LID ASSEMBLY - 115V	1
	4314121	EVAPORATOR FAN LID ASSEMBLY - 220V	
1	4314090	SEAL - EVAPORATOR - OUTLET	1
2	4311211	GASKET - FOAM - 1/8 X 1/2	1
3	4314124	INSULATION - .12 - TOP - OUTER	1
4	4314070	WRAPPER - EVAPORATOR TOP	1
5	4751060	RETAINER - HARNESS	2
6	4314092	SPACER - FAN & COVER - EVAPORATOR	1
7	4314014	FAN - EVAPORATOR - AXIAL	1
8	4402043	NUT - #8-32 W/L.W.-S.S.	2
9	3104124	SCREW - #8-32 X 5/8 PHS SS	2



431p0122

FIGURE 39: STOP PIN/SOLENOID ASSEMBLY

TABLE 39: STOP PIN/SOLENOID ASSEMBLY

INDEX	PART NUMBER	DESCRIPTION	QTY
--	4311108	STOP PIN / SOLENOID ASSEMBLY - 115V	REF
	4311109	STOP PIN / SOLENOID ASSEMBLY - 230V	
1	4311204	BRACKET - STOP PIN ASSEMBLY	1
2	9900164	NUT #10-32 KEPS ZINC PLATE	1
3	4311080	BRACKET - SOLENOID & SWITCH X MOUNTING	1
4	1217159	4-40 KEPS W/EXT L/WAS H ZP	2
5	9900032	LOCKWASHER #8 SPLIT TYPE ZINC PLATE	2
6	9900106	SCREW #8-32 X 3/8 ACCRN HEX HD - S/T	4
7	2342315	CLIP - WIRE HARNESS	1
8	4245186	SCREW #8-32 X 1/4 PHS T/F	1
9	4301364	BUSHING - RETAINER	1
10	6112042	INSULATOR - SWITCH	1
11	2304109	SWITCH ROLLER LEVER	1
12	1217160	4 - 40 X 5/8 RHS M SCREW Z/Y	2
13	4311105	MECHANISM ASSEMBLY - STOP PIN - DOMESTIC - 115V	1
	4311106	MECHANISM ASSEMBLY - STOP PIN - FOREIGN - 230V	
14	9900107	SCREW #6-32 X 5/16 - RHS - W/LKW	4
15	4311076	SPRING - EXTENSION	1
16	4311079	PLATE - COVER - BOTTOM (NOT PART OF ASSEMBLY)	1
17	4311205	PLATE - COVER (NOT PART OF ASSEMBLY)	1
18	6104411	SCREW #10-32 X 1 1/2 - PHS - N/LKW - STAIN - STL	1
19	6138181	WASHER PLATE	1
20	4311077	LEVER ACTUATOR - SWITCH - DELAY & STOP PIN	1
21	4311075	BUSHING	1
22	4301375	GROOVE PIN - .125 DIA X .875	1
23	4311082	CAM - SWITCH - DELAY	1
24	4311074	PIN - STOP	1
25	6104216	ROLL PIN	1
26	9900078	NUT #6-32 - KEPS - Z/P	4

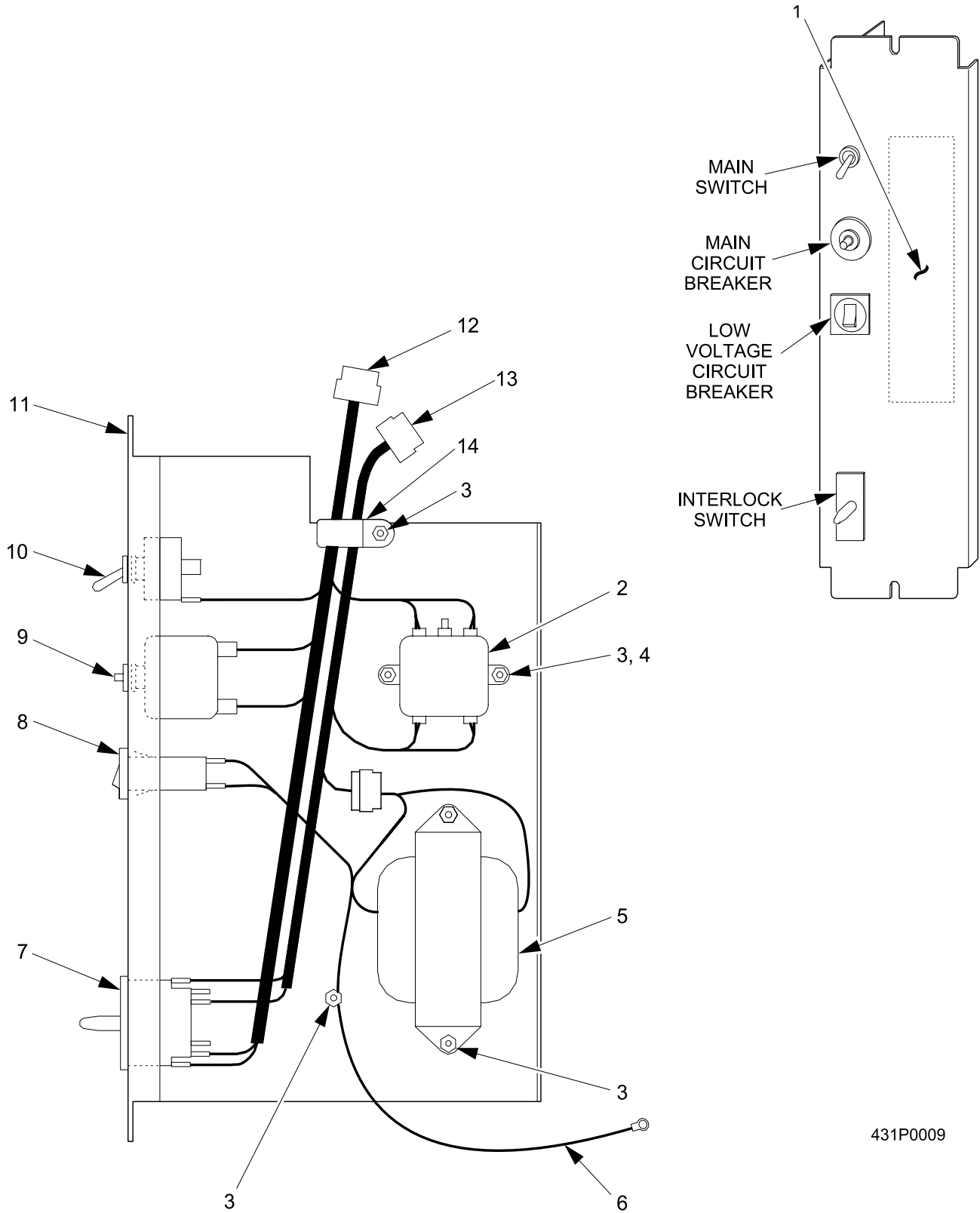
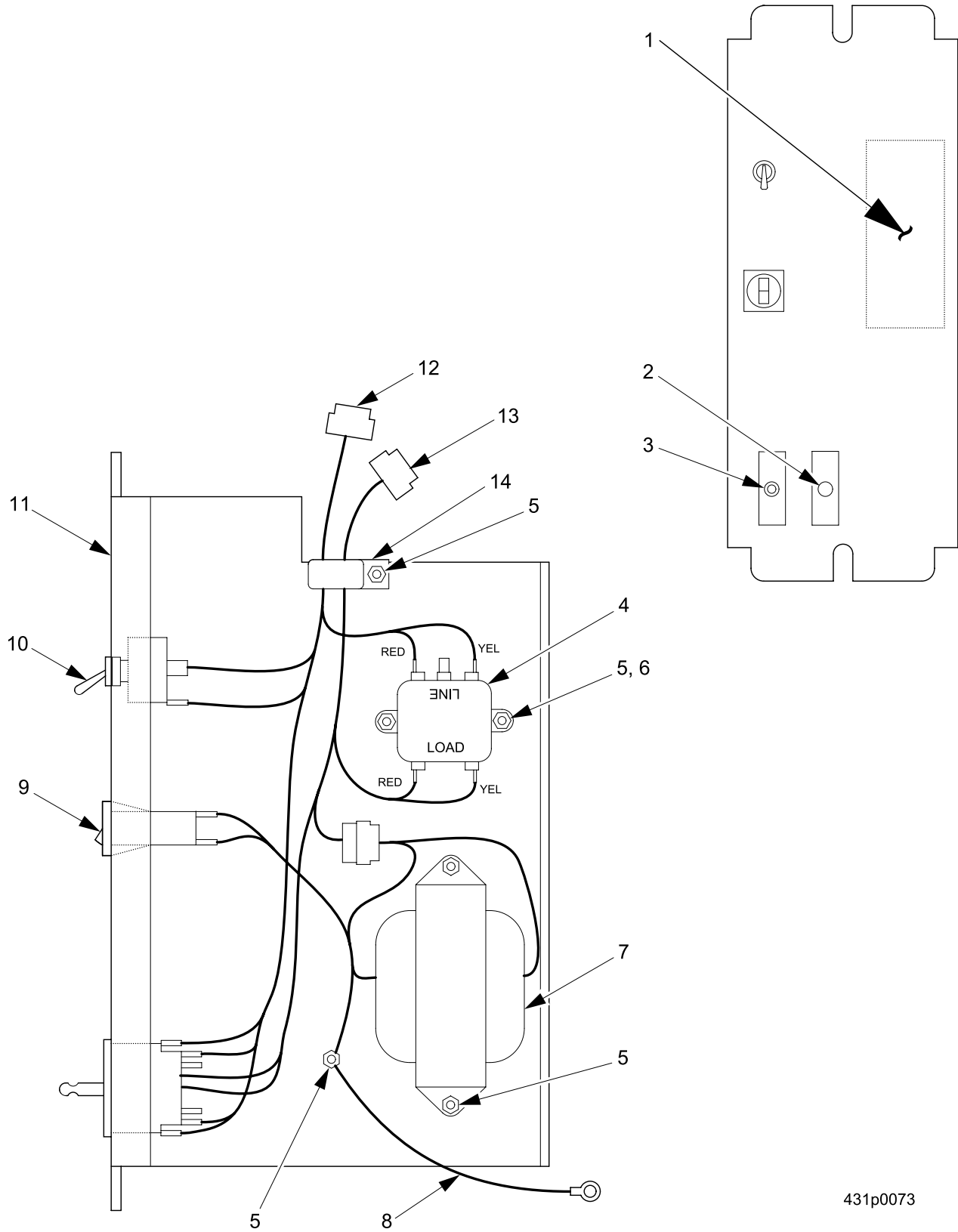

FIGURE 40: POWER PANEL ASSEMBLY - 115 V

TABLE 40: POWER PANEL ASSEMBLY - 115 V

INDEX	PART NUMBER	DESCRIPTION	QTY
--	4311171	POWER PANEL ASSEMBLY - DOMESTIC	--
--	9989369	LABEL - N.V. - BLANK	1
1	4311117	LABEL - POWER CONTROL PANEL - 115V - ENGLISH	1
2	9989100	INTERFERENCE FILTER	10
3	9900081	NUT - #8-32 KEPS ZINC PLATE	2
4	1211110	8-32 X 1/4 RHS MACH SCREW ZIP	1
5	9989042	TRANSFORMER - 115V/230V PRIMARY 24V SECONDARY	1
6	9984094	WIRE - GROUND - 14"	1
7	1211141	SWITCH	1
8	9989336	CIRCUIT BREAKER - 3 AMP	1
9	9989673	CIRCUIT BREAKER - 20 AMP	1
10	9984629	SWITCH - TOGGLE - DPST - 20 AMP	1
11	4311168	CONTROL PANEL ASSEMBLY - POWER	1
12	4319001	HARNESS - POWER PANEL	1
13	4319003	HARNESS - POWER PANEL XFMR-DOM.	1
14	4751060	RETAINER - HARNESS	1



431p0073

FIGURE 41: POWER PANEL ASSEMBLY - U.K.

TABLE 41: POWER PANEL ASSEMBLY - U.K.

INDEX	PART NUMBER	DESCRIPTION	QTY
--	4311173	POWER PANEL ASSEMBLY - UK	--
1	4310027	LABEL - ASSEMBLY - I.D. - 230V	1
2	2366135	SWITCH - INTERLOCK	1
3	1211141	SWITCH	1
4	9989100	INTERFERENCE FILTER	1
5	9900081	NUT #8-32 KEPS ZINC PLATE	6
6	1211110	8-32X1/4 RHS MACH SCR ZP	2
7	9989042	TRANSFORMER - 115V/230V PRIMARY 24V SECONDARY	1
8	9984094	WIRE - GROUND - 14"	1
9	9989336	CIRCUIT BREAKER - 3 AMP	1
10	9984629	SWITCH - TOGGLE - DPST - 20 AMP	1
11	4311170	CONTROL PANEL ASSEMBLY - POWER - UK	1
12	4319016	HARNESS - POWER PANEL - 230V	1
13	4319013	HARNESS - POWER PANEL TRANSFORMER - 230V	1
14	4751060	RETAINER - HARNESS	1

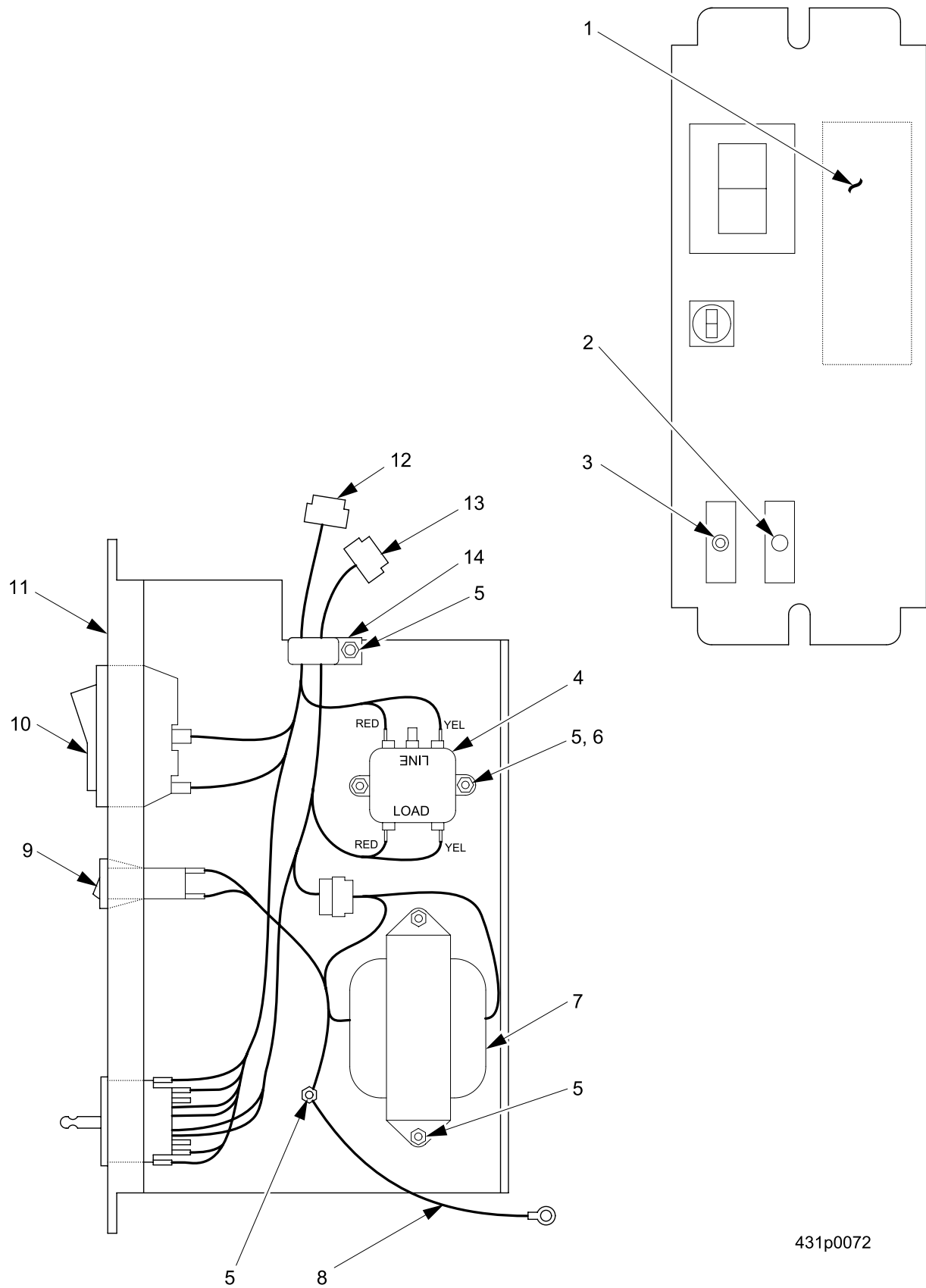

431p0072

FIGURE 42: POWER PANEL ASSEMBLY - 230 V

TABLE 42: POWER PANEL ASSEMBLY - 230 V

INDEX	PART NUMBER	DESCRIPTION	QTY
--	4311172	POWER PANEL ASSEMBLY - 230V	--
1	4310027	LABEL - ASSEMBLY - I.D. - 230V	1
2	2366135	SWITCH - INTERLOCK	1
3	1211141	SWITCH	1
4	9989100	INTERFERENCE FILTER	1
5	9900081	NUT #8-32 KEPS ZINC PLATE	6
6	1211110	8-32X1/4 RHS MACH SCR ZP	2
7	9989042	TRANSFORMER - 115V/230V PRIMARY 24V SECONDARY	1
8	9984094	WIRE - GROUND - 14"	1
9	9989336	CIRCUIT BREAKER - 3 AMP	1
10	9984627	CIRCUIT BREAKER/SWITCH - 16 AMP	1
11	4311169	CONTROL PANEL ASSEMBLY - POWER - 230V	1
12	4319016	HARNESS - POWER PANEL - 230V	1
13	4319013	HARNESS - POWER PANEL TRANSFORMER - 230V	1
14	4751060	RETAINER - HARNESS	1

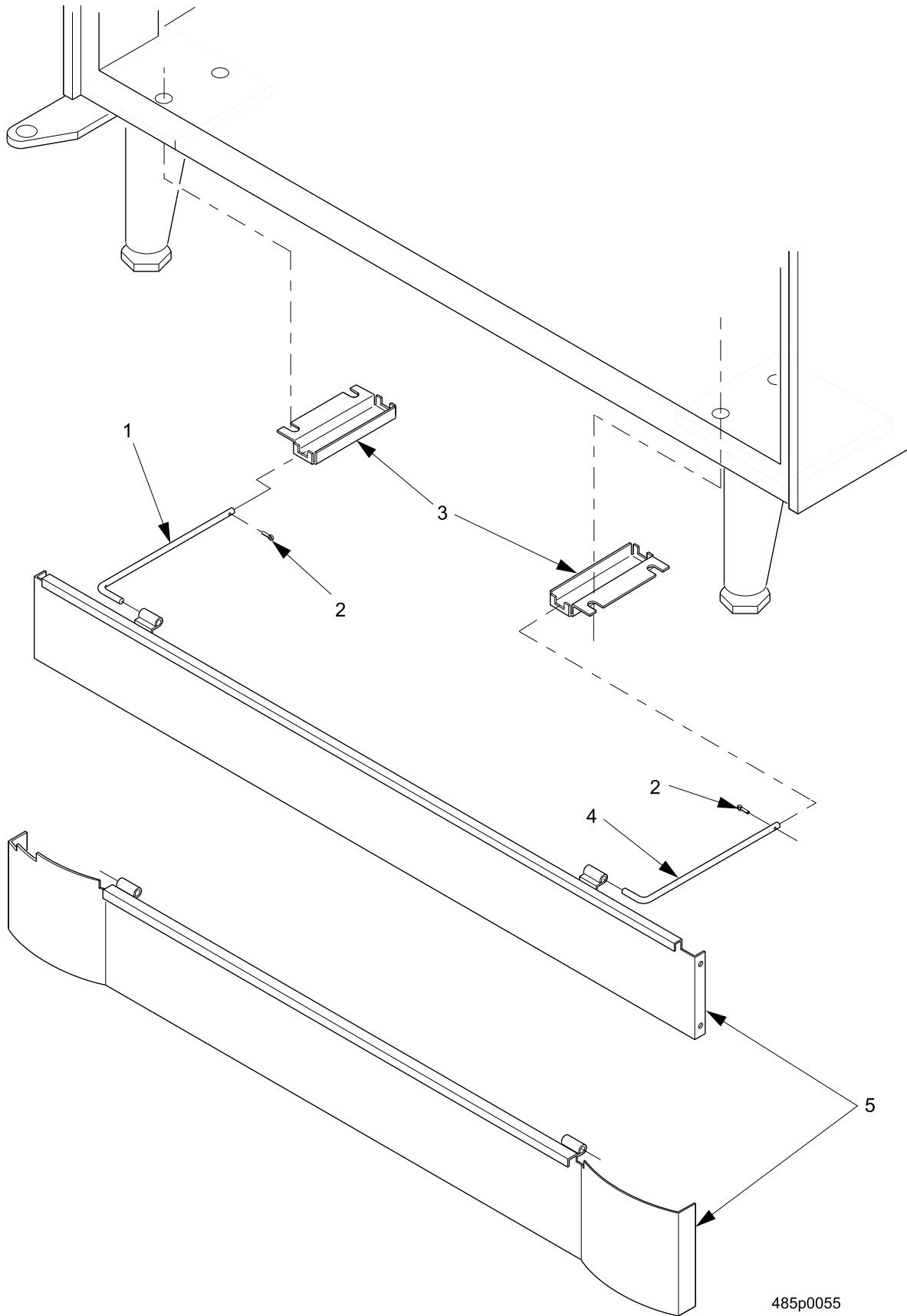

485p0055

FIGURE 43: BASE PLATE ACCESSORY

TABLE 43: BASE PLATE ACCESSORY

INDEX	PART NUMBER	DESCRIPTION	QTY
--	4311194	BASE PLATE AND ACCESSORY ASSEMBLY STANDARD BLACK	REF.
	4311190	BASE PLATE AND ACCESSORY ASSEMBLY - 38" - MILLENNIA	
1	4551153	SLIDE - BASE PLATE - LEFT HAND	1
2	9900098	COTTER PIN 3/32 X 3/4 LONG	2
3	4311071	BRACKET - BASE PLATE	2
4	4551154	SLIDE - BASE PLATE - RIGHT HAND	1
5	2271408	BASE PLATE ASSEMBLY - NV BLACK	1
	1571161	BASE PLATE ASSEMBLY - 38" MILLENNIA	

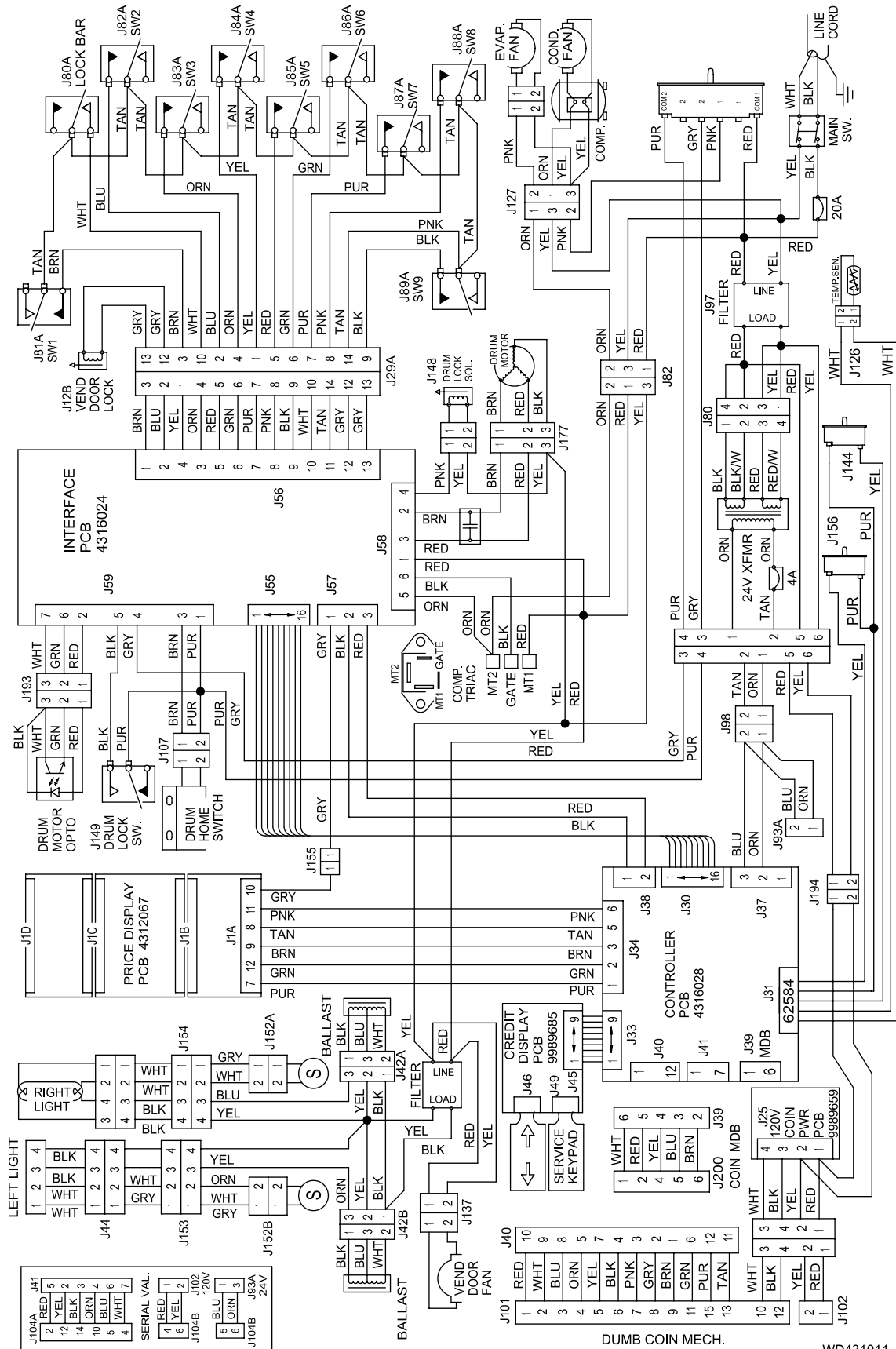
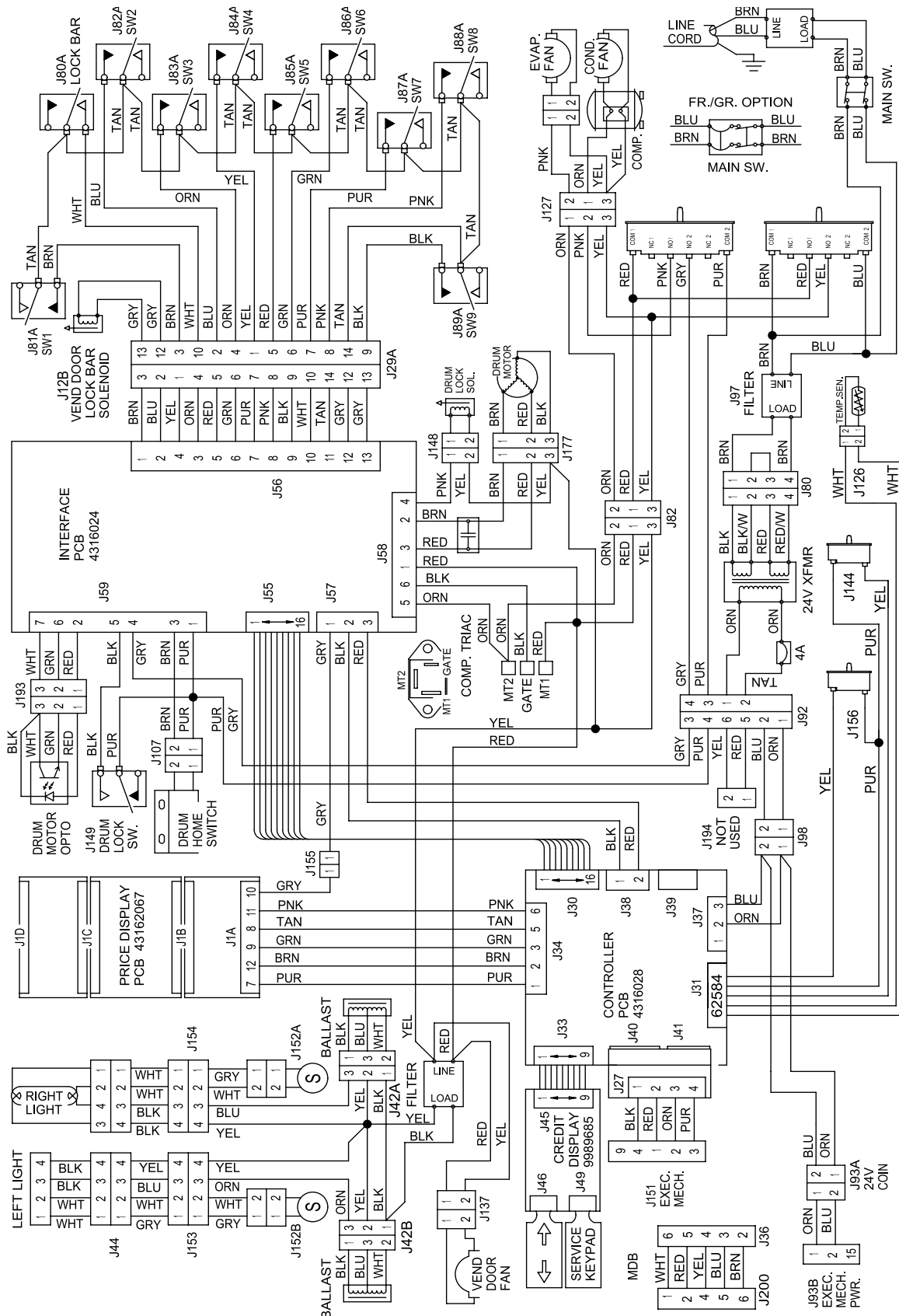

FIGURE 44: WIRING DIAGRAM - 120V

WD431011



WD431012

FIGURE 45: WIRING DIAGRAM - 230V

**TABLE 44: WIRE HARNESES
(USE WITH YOUR WIRING DIAGRAM)**

INDEX	PART NUMBER	DESCRIPTION	COUNTRY CODE (SEE BELOW)												
			A	D	E	F	G	H	L	M	N				
1	4319001	HARNESS - POWER PANEL													
2	4319003	HARNESS - POWER PANEL TRANSFORMER DOM													
3	4314046	HARNESS - COMPRESSOR													
4	4319024	HARNESS - CABINET AC													
5	4319023	HARNESS - POWER TO FLUORESCENT LIGHT													
6	4319026	HARNESS - FLUORESCENT LIGHT (SEE TABLE 28 FOR DETAILS)													
7	4302277	HARNESS - LOWER FLUORESCENT LIGHT (SEE TABLE 27 FOR DETAILS)													
8	4302276	HARNESS - UPPER FLUORESCENT LIGHT (SEE TABLE 27 FOR DETAILS)													
9	4319005	HARNESS - CABINET - DC													
10	4319031	HARNESS - CONTROLLER TO VERTICAL DISPLAY													
11	4319032	CABLE ASSEMBLY - 16 CONDUCTER													
12	4319014	HARNESS - MECHANISM TO BOARD													
13	4319030	HARNESS - MECHANISM - VEND DOOR SWITCH													
14	4319010	HARNESS - POWER TO COIN HANDLING													
15	1579003	HARNESS - COIN MECHANISM													
16	1599200	HARNESS - CONTROL TO DISPLAY													
17	4319027	HARNESS - 24V - TEMP & SWITCH													
18	4319025	HARNESS - FLUORESCENT POWER													

HARNESSES NOT SHOWN

--	1679054	HARNESS - MDB COIN & VALIDATOR													
--	4319013	HARNESS - POWER PANEL XFMR - 230V													
--	4319016	HARNESS - POWER PANEL - 230V													
--	1475119	JUMPER - GROUND WIRE													
--	9989637	JUMPER - BLOWER													
--	9989577	POWER CORD - EURO PLUG													
--	9984094	WIRE - GROUND - 14													
--	1679053	HARNESS - SERIAL VALIDATOR													
--	1579032	HARNESS - SERIAL VALIDATOR - 24V													
--	1579034	HARNESS FOR BA 30/32 SA - MDB													

COUNTRY CODE DEFINITIONS

A = ARGENTINA D = USA E = U.K. F = FRANCE G = GERMANY
H = AUSTRALIA NEW ZEALAND SWEDEN L = BRAZIL SAUDI ARABIA M = MEXICO
N = NAVY 220V

**TABLE 44: WIRE HARNESSSES (CONTINUED)
(USE WITH YOUR WIRING DIAGRAM)**

INDEX	PART NUMBER	DESCRIPTION	COUNTRY CODE (SEE BELOW)											
			A	D	E	F	G	H	L	M	N			
--	1579050	HARNESS FOR MDB - CONLUX 2000												
--	1475117	HARNESS - INTERFACE - DEBIT - VAL. - CM.												
--	1579018	HARNESS - DATA PRINTER INTERFACE												
--	1679056	HARNESS - DEX INTERFACE												
--	9989631	JUMPER - DEBIT CARD - SHOPPER												
--	9989718	JUMPER - VALIDATOR - 24V												
--	4305080	CABLE ASSEMBLY - RIBBON												
--	9989781	POWER CORD - 14AWG - DOMESTIC												
--	9989116	JUMPER - EMI FILTER - 25												
--	9989576	POWER CORD - W/BSI PLUG												

COUNTRY CODE DEFINITIONS

**A = ARGENTINA D = USA E = U.K. F = FRANCE G = GERMANY
H = AUSTRALIA NEW ZEALAND SWEDEN L = BRAZIL SAUDI ARABIA M = MEXICO
N = NAVY 220V**

TABLE 45: BAG ASSEMBLY B4310000 - US

PART NUMBER	DESCRIPTION	QTY
WD431011	WIRING DIAGRAM - 431 SHOPPER - 120V	1
1475094	LABEL - INSTRUCTIONS - ALT \$1 & \$5 - EXT.	1
4302195	DECAL - INSTRUCTIONS	1
4302230	DECAL - TRAY PRICE	1
4310114	OPERATOR'S GUIDE - SHOPPERTRON	1

TABLE 46: BAG ASSEMBLY B4310002 - FRANCE

PART NUMBER	DESCRIPTION	QTY
WD431012	WIRING DIAGRAM - 431 SHOPPER - 230V	1
4302248	LABEL - INSTRUCTIONS - SHOPPERTRON - FR.	1
4302230	DECAL - TRAY PRICE	1
4310045	SPECIAL INSTRUCTIONS - CE - FRENCH	1
4310114	OPERATOR'S GUIDE - SHOPPERTRON	1

TABLE 47: BAG ASSEMBLY B4310003 - GERMANY

PART NUMBER	DESCRIPTION	QTY
WD431012	WIRING DIAGRAM - 431 SHOPPER - 230V	1
4302195	DECAL - INSTRUCTIONS	1
4302230	DECAL - TRAY PRICE	1
4310047	SPECIAL INSTRUCTIONS - CE - GERMAN	1
4310114	OPERATOR'S GUIDE - SHOPPERTRON	1

TABLE 48: BAG ASSEMBLY B4310005 - NEW ZEALAND

PART NUMBER	DESCRIPTION	QTY
WD431012	WIRING DIAGRAM - 431 SHOPPER - 230V	1
1575083	COIN CHUTE & BRACKET ASSEMBLY	1
1575086	INSTRUCTIONS SHEET - COIN CHUTE & BRACKET	1
4302195	DECAL - INSTRUCTIONS	1
4302230	DECAL - TRAY PRICE	1
4310114	OPERATOR'S GUIDE - SHOPPERTRON	1

TABLE 49: BAG ASSEMBLY B4310011 - 5-14-20-21

PART NUMBER	DESCRIPTION	QTY
WD431011	WIRING DIAGRAM - 431 SHOPPER - 120V	1
WD431012	WIRING DIAGRAM - 431 SHOPPER - 230V	1
4302230	DECAL - TRAY PRICE	1
4304107	DECAL - INSTRUCTIONS - SPANISH	1
4310046	SPECIAL INSTRUCTIONS - CE - SPANISH	1
4310047	SPECIAL INSTRUCTIONS - CE - GERMAN	1
4310114	OPERATOR'S GUIDE - SHOPPERTRON	1

Shoppertron Parts Manual

Part Number Index

Part Number	Page	Part Number	Page	Part Number	Page
1101906	33	1571034	21	3152447	6
1122521	33	1571035	21	3157060	21, 57, 59
1141043	53	1571161	89	4031149	57, 59
1141046	33, 45	1572102	7	4031150	21
1141057	47	1572104	7	4041057	33
1171021	63	1572107	7	4042121	21
1171022	63	1572110	7	4043066	75
1171052	63	1572113	7	4076510	23
1172190	25, 27	1572116	7	4076515	35
1172191	25, 27	1572119	7	4111149	55
1172261	63	1572124	7	4241135	21
1172262	63	1572127	7	4241160	29, 51
1211105	65	1572128	6	4241162	55
1211110	21, 83, 85, 87	1572131	7	4241165	45
1211141	83, 85, 87	1572150	7	4241235	35
1212117	37	1572153	7	4241264	67
1212140	55	1572158	7	4242145	65
1217159	81	1572167	7	4244009	73
1217160	81	1572236	5	4244026	73
1236050	19	1572258	5	4245186	81
1272039	37	1572267	5	4252029	23
1272044	37	1572324	5	4254027	73
1272131	37	1572325	5	4255026	37
1272132	37	1572327	5	4271062	55, 71
1302289	25, 27	1572432	5	4301038	49
1302290	25, 27	1575083	94	4301039	49
1302291	25, 27	1575086	94	4301045	49
1302324	25, 27	1579003	92	4301049	53
1302326	25, 27	1579018	93	4301143	53
1302478	3	1579028	43	4301151	51
1302479	3	1579032	43, 92	4301205	55
1402014	35	1579034	92	4301206	55
1402100	19	1579050	43, 93	4301216	53
1451097	17, 19, 33	1599200	39, 92	4301222	53, 67
1451334	45	1679053	92	4301230	51
1452062	6	1679054	92	4301235	51
1452116	6	1679056	93	4301254	51
1452117	6	2222110	15	4301256	63
1452118	6	2222714	53	4301285	49
1452121	6	2271408	89	4301351	55
1452139	55, 59, 71	2272052	25, 27, 37	4301353	67
1452191	35	2302053	35, 37	4301364	81
1452225	6	2302227	23	4301368	55
1470761	33	2304109	81	4301374	55
1471098	49	2342315	19, 57, 81	4301375	55, 71, 81
1471199	49	2366135	85, 87	4301378	55, 71
1471237	49	3104124	79	4301380	55, 71
1472222	37	3106155	13	4301394	55
1472223	37	3112163	25, 27	4301395	55
1472251	39	3112164	25, 27	4301396	55
1475094	94	3122154	29	4301521	55, 71
1475099	39	3124031	73	4301524	55
1475117	93	3127034	55	4301525	71
1475119	57, 92	3152398	63	4302022	33

Part Number Index

Shoppertron Parts Manual

Part Number	Page	Part Number	Page	Part Number	Page
4302028	29	4302245	59	4305062	35
4302029	29	4302248	94	4305069	39
4302030	9	4302269	15	4305071	39
4302032	45	4302272	3	4305077	39
4302034	9	4302274	3	4305080	93
4302035	31	4302276	57	4305088	37
4302036	29	4302277	57, 92	4305100	6
4302037	63	4302280	3	4305105	37
4302039	45, 47	4302282	3	4305112	6
4302040	47	4302284	6	4305113	6
4302041	63	4302285	6	4305114	37
4302049	45	4302288	6	4305131	37
4302050	47	4302315	23	4305138	6
4302055	45	4302316	23	4305140	6
4302069	57, 59	4302318	23	4305141	6
4302078	17	4302320	23	4305144	6
4302079	5, 17	4302324	23	4305145	6
4302082	13	4302329	23	4307009	67, 69
4302086	57, 59	4302332	23	4307015	67
4302089	9	4302338	23	4307017	67
4302090	45	4302345	23	4307018	67
4302097	31	4302348	23	4307024	69
4302098	31	4302350	23	4307026	67
4302105	15	4302360	23	4307027	67, 69
4302106	9	4302373	6	4307028	67, 69
4302109	5, 11	4302384	29	4307032	67
4302113	15	4302385	29	4307034	67, 69
4302115	3	4302386	9	4307035	67, 69
4302117	15	4302390	9	4307036	67, 69
4302118	15	4302391	9	4307038	67
4302119	17	4302396	57, 59	4307045	67
4302120	13	4302398X	19, 59	4307046	67, 69
4302121	3	4302401	15	4310027	85, 87
4302124	3	4302407	15	4310045	94
4302136	9	4302408	33	4310046	94
4302143	15, 31	4302414	13	4310047	94
4302144	33	4302415	6	4310114	94
4302145	15	4302569	59	4311007	5
4302163	33	4302646	59	4311009	51
4302181	9	4302647	59	4311012	57, 59
4302187X	19, 59	4304067	73	4311022	51
4302191	33	4304107	94	4311042	51
4302195	94	4304194	73	4311054	67
4302206	17	4304195	73	4311055	67
4302213	31	4304220	73	4311058	51
4302214	31	4304231	75	4311068	49
4302222	15	4305010	6	4311071	89
4302223	23	4305011	37	4311074	81
4302224	23	4305026	35	4311075	81
4302230	94	4305027	37	4311076	81
4302231	49	4305043	21, 45	4311077	81
4302232	49	4305048X	37	4311079	81
4302236	11	4305050	35	4311080	81
4302237	33	4305052	6	4311082	81

Shoppertron Parts Manual

Part Number Index

Part Number	Page	Part Number	Page	Part Number	Page
4311083	57, 59	4312060	33	4312231	5
4311096	63	4312061	33	4312234	6
4311105	81	4312063	33	4312236	6
4311106	81	4312065	21	4312238	6
4311108	55, 81	4312067	11	4312243	23
4311109	55, 81	4312072	19, 57	4312264	17
4311117	83	4312078	19, 57	4312272	19
4311124	55, 71	4312081	17	4314014	79
4311125	71	4312083	17	4314027	73
4311126	55, 71	4312084	9	4314034	75
4311127	71	4312090	5	4314035	75
4311139	21	4312091	65	4314036	75
4311156	51	4312093	65	4314037	73
4311168	83	4312094	5	4314040	73
4311169	87	4312095	5, 13	4314041	73
4311170	85	4312096	5, 13	4314044	73
4311171	49, 83	4312108	63	4314045	73
4311172	49, 87	4312116	6	4314046	92
4311173	49, 85	4312123	17	4314055	73
4311175	51	4312124	15	4314065	73
4311178	51	4312127	15	4314070	79
4311179	51	4312130	17, 57	4314071	73
4311190	5	4312131	57	4314079	53
4311190X	89	4312132	17, 57	4314089	75
4311194X	89	4312133	57	4314090	79
4311200	51	4312135	63	4314092	79
4311204	81	4312138	5	4314096	77
4311205	81	4312144	11	4314098	77
4311211	79	4312145	31	4314099	77
4311216	55, 71	4312146	5	4314100	77
4311219	55	4312200	5	4314101	77
4311220	55	4312201	5	4314102	77
4311224	67	4312202	5	4314103	77
4311225	67	4312203	5	4314104	77
4311227	55	4312205	5	4314105	77
4311229	55	4312207	29	4314106	77
4311235	63, 65	4312208	29	4314107	77
4311236	33	4312209	29	4314110	51
4311237	55	4312210	61	4314111	51
4311250	19, 21	4312211	61	4314114	73
4312006	63	4312212	63	4314119	79
4312007	63	4312213	55	4314121	79
4312008	21	4312214	13	4314124	79
4312009	19	4312215	11, 13, 15	4314125	77
4312010	19, 61	4312216	23	4314133	73
4312011	61	4312217	11, 13, 17	4315001	39
4312015	61	4312218	45	4315007	45
4312016	61	4312219	29	4315012	37
4312017	21	4312220	29	4315013	37
4312028	7	4312221	29	4315014	37
4312048	7	4312222	29	4315015	37
4312050	19, 61	4312223	29	4315022	6
4312055	19	4312227	13	4315025	6
4312057	33	4312228	13	4315028	6

Part Number Index

Shoppertron Parts Manual

Part Number	Page	Part Number	Page	Part Number	Page
4315030	39	5900097	45	9900098	35, 89
4315032	6, 37, 39	5900112	45	9900106	9, 15, 21, 31, 35, 45, 81
4315040	6	5900116	45	9900107	81
4315041	37	5900194	43	9900118	55, 71
4315043	6	5900206	43	9900156	9, 29
4315054	6	5900209	45	9900160	9, 53, 55, 71
4315069	37	5900211	43	9900164	81
4315070	37	5900213	45	9900170	25, 27
4316024	21	5900214	45	9900203	39
4316028	45	5900216	45	9900204	33
4316036	45	5900235	43	9900207	47
4317001	49, 67	5900243	45	9900218	49
4317002	67	5900244	45	9900219	57, 59
4317003	67	5900246	43	9900425	37
4317004	53	5900249	43	9900437	55
4317006	67	5900250	43	9901840	53
4317008	49, 67	5900267	43	9901897	51
4317011	67	5900269	45	9983778	21
4317012	67	5900272	43	9984094	21, 83, 85, 87, 92
4319001	83, 92	5900276	45	9984627	87
4319003	83, 92	5900279	45	9984629	83, 85
4319005	92	5900283	43	9984633	23
4319008	21	5900284	43	9984637	23
4319010	21, 92	5900285	43	9987852	19
4319012	55	6104216	81	9988210	21
4319013	85, 87, 92	6104411	81	9988211	21
4319014	92	6106021	13	9989042	83, 85, 87
4319016	85, 87, 92	6111041	45	9989100	21, 83, 85, 87
4319023	92	6112042	23, 81	9989110	53
4319024	21, 92	6131066	25, 27	9989116	93
4319025	92	6138181	47, 81	9989336	83, 85, 87
4319026	59, 92	6231035	21	9989369	83
4319027	19, 92	6232099	3	9989576	93
4319030	92	6232224	6	9989577	92
4319031	92	6232309	6	9989628	39
4319032	92	6234295	35	9989631	93
4329022	55	6312013	5	9989637	92
4402043	79	6312014	5	9989649	29, 31
4551153	89	6312015	5	9989659	21
4551154	89	6335002X	39	9989673	83
4551156	49	6335005	39	9989718	93
4552058	5	6400002	45	9989755	45
4552059	5	6400003	45	9989781	93
4552060	5	8905012	27	9989823	39
4614027	77	9084349	73	9992400	25, 27
4744031	75	9900019	59	9994000	27
4751060	75, 79, 83, 85, 87	9900032	81		
4872007	5	9900035	11	B	
4872008	5	9900039	33	B431000	94
4872009	5	9900071	57, 59	W	
4872013	5	9900078	81	WD431011	94
5264629	63	9900081	15, 21, 39, 59, 83, 85,	WD431012	94
5277437	67		87		

Terms and Conditions of Sale

LIMITED WARRANTY: Subject to the limitation specified herein, all parts included on original equipment manufactured by CRANE MERCHANDISING SYSTEMS and sold to purchaser are warranted for two (2) years from the date of shipment of the equipment in question. This warranty applies only to the original purchaser of the Merchandiser and is null and void if the Merchandiser is sold during the period of warranty.

Defective parts will be repaired or replaced free of charge when the defective part is returned, with transportation charges prepaid by purchaser, to a destination designated by CRANE MERCHANDISING SYSTEMS.

This warranty does not include any cost of service rendered or repairs made by customer or its agents on Merchandiser, or parts, unless authorization to incur such expense has been given in writing by CRANE MERCHANDISING SYSTEMS prior to incurring such expense. This warranty does not cover labor and service charges performed by CRANE MERCHANDISING SYSTEMS service technicians.

This warranty does not apply to A) electrical components, wiring, or circuits or mechanical parts or assemblies damaged as a result of operating the Merchandiser at other than the design voltage and frequency specified on the Electrical Rating Tag, or B) in event of vandalism, fire or negligence, or C) incandescent lamps, neon lamps, fluorescent lamps, ballasts, starters or other expendable items, or D) when seal is broken on electronic boards, or E) when other manufactured components are installed in CRANE MERCHANDISING SYSTEMS Merchandisers.

Replacement parts sold by CRANE MERCHANDISING SYSTEMS as After Market shall be covered for three months from the date shown on the parts invoice. Purchaser must obtain prior RETURN AUTHORIZATION for return of all parts, following guidelines given by CRANE MERCHANDISING SYSTEMS.

New, unused parts purchased as After Market can be returned within 30 days from date of parts invoice, with prior authorization from CRANE MERCHANDISING SYSTEMS.

THIS WARRANTY IS IN LIEU OF ALL OTHER WARRANTIES EXPRESS OR IMPLIED, INCLUDING WITHOUT LIMITATION, WARRANTIES OF MERCHANTABILITY OF FITNESS FOR A PARTICULAR PURPOSE. CRANE MERCHANDISING SYSTEMS SHALL NOT BE RESPONSIBLE FOR CONSEQUENTIAL OR PUNITIVE DAMAGES. CRANE MERCHANDISING SYSTEMS neither assumes nor authorizes any person to assume for it any obligation or liability in connection with the sale of said equipment or any part thereof.

